



LVE

**CHAMPS
TRADE SHOWS**

CHAMPS AUGUST 2026

Las Vegas Convention Center

Halls S1 - S2

August 26 - 28, 2026

Exhibitor Service Manual

888-989-EXPO

LAS VEGAS • ORLANDO • NASHVILLE • DALLAS • DENVER • SOCAL

TABLE OF CONTENTS

| | |
|---------|---|
| 3 | IMPORTANT DATES |
| 4 | FREE FURNISHINGS - REQUIRED TO BE RETURNED |
| 5 - 6 | SHOW INFORMATION |
| 7 - 8 | HAND CARRY RULES |
| 9 - 12 | SOUND & HEIGHT RESTRICTIONS & BOOTH CONSTRUCTION GUIDELINES |
| 13 | WELCOME LETTER |
| 14 | PAYMENT AUTHORIZATION |
| 15 - 16 | FURNITURE & ACCESSORIES |
| 17 - 18 | SHELVING UNITS & SHOW CASES |
| 19 - 20 | CARPET ORDER & COLOR SAMPLES |
| 21 | BOOTH CLEANING & PORTER SERVICE |
| 22 - 24 | GRAPHICS & SIGNS |
| 25 | DISPLAY LABOR |
| 26 - 32 | MATRIX & AGAM RENTAL EXHIBIT PACKAGES & ACCESSORIES |
| 33 - 35 | EAC WORK AUTHORIZATION, AGREEMENT & FEES, 3RD PARTY |
| 36 | MATERIAL HANDLING |
| 37 | WAREHOUSE DELIVERY LABELS |
| 38 | DIRECT TO SHOW SITE LABELS |
| 39 | CLOSE OF SHOW INSTRUCTIONS |
| 40 | CREATE YOUR OWN HANGING SIGN |
| 41 | HANGING SIGN GUIDELINES |
| 42 | NON-ELECTRICAL HANGING SIGN - UNDER 200 LB |
| 43 | ELECTRICAL SIGNS / MOTORS / HANGING OF VIDEO WALLS |
| 44 - 45 | STRUCTURAL INTEGRITY STATEMENT & SIGN PLACEMENT |
| 46 | RUSH - HANGING SIGN LABELS |
| 47 | PREFERRED CARRIER - LVE LOGISTICS powered by AIRWAYS |
| 48 | VEHICLE SPOTTING SUBMISSION |
| 49 - 50 | LIMITS OF LIABILITY & RESPONSIBILITY |
| 51 - 52 | SHOW SITE WORK RULES / FIRE & SAFETY REGULATIONS |
| 53 | FREQUENTLY ASKED QUESTIONS |
| 54 - 66 | SPECIALTY FURNITURE (ANGLES ON DESIGN) |
| 67 - 85 | LAS VEGAS CONVENTION CENTER RULES & REGULATIONS |
| 86 - 93 | INTERNET / WIFI (COX COMMUNICATION) |
| 94 - 95 | AUDIO VISUAL (TST) |
| 96 - 99 | ELECTRICAL (CTS) |

IMPORTANT DATES

LVE now has 3-tier pricing. Order by the discount date to take advantage of the best pricing.

| <i>DESCRIPTION</i> | DISCOUNT RATES RECEIVED BY | STANDARD RATES BEGIN | ONSITE RATES BEGIN |
|---|--|-------------------------------------|-----------------------------------|
| BOOTH PACKAGE (REQUIRED TO BE RETURNED) | 8/5/2026 | 8/6/2026 | 8/20/2026 |
| <i>FURNITURE</i> | 8/5/2026 | 8/6/2026 | 8/20/2026 |
| <i>ACCESSORIES</i> | 8/5/2026 | 8/6/2026 | 8/20/2026 |
| <i>SHELVING UNITS</i> | 8/5/2026 | 8/6/2026 | 8/20/2026 |
| <i>SHOWCASES</i> | 8/5/2026 | 8/6/2026 | 8/20/2026 |
| <i>CARPET</i> | 8/5/2026 | 8/6/2026 | 8/20/2026 |
| <i>BOOTH CLEANING & PORTER SERVICE</i> | 8/5/2026 | 8/6/2026 | 8/20/2026 |
| <i>DISPLAY LABOR</i> | 8/5/2026 | 8/6/2026 | 8/20/2026 |
| <i>RENTAL BOOTH PACKAGES</i> | 8/5/2026 | 8/6/2026 | 8/20/2026 |
| <i>NON-ELECTRICAL HANGING SIGN - UNDER 200 LB</i> | 8/5/2026 | 8/6/2026 | 8/20/2026 |
| <i>ELECTRICAL SIGNS / MOTORS / HANGING OF VIDEO WALLS</i> | 8/5/2026 | 8/6/2026 | 8/20/2026 |
| MATERIAL HANDLING | Begins | | Ends |
| Advance Warehouse Shipments Standard Rates | 7/20/2026 | - | 8/10/2026 |
| Hanging Signs to Advance Warehouse | 7/20/2026 | - | 8/10/2026 |
| Late Advance Warehouse Shipments | 8/11/2026 | - | 8/28/2026 |
| Direct to Show Shipments Standard Rates | 8/23/2026 | - | 8/24/2026 |
| Late Direct to Show Shipments | Received after the show has opened | | |
| WORK AUTHORIZATION | DEADLINE: Wednesday, August 5, 2026 | | |
| EAC AGREEMENT & FEES | DEADLINE: Wednesday, August 5, 2026 | | |
| VEHICLE SPOTTING SUBMISSION | DEADLINE: Monday, July 20, 2026 | | |

Specialty Furniture, Electrical, Internet, etc

See individual forms for deadlines

CHAMPS LAS VEGAS AUGUST 2026
AUGUST 26 - 28, 2026
LAS VEGAS CONVENTION CENTER - S1 & S2
COMPANY NAME
BOOTH #
FREE FURNISHINGS - REQUIRED TO BE RETURNED
20' x 20' Booths and Larger MUST COMPLETE and RETURN

Each exhibitor with a 20' x 20' booth or larger must complete the following to take advantage of the "Free Furniture". This does not apply to the smaller inline booths.

Please return via email exhibitorservices@lvexpo.com or fax 702-248-4113

DEADLINE DATE: August 5, 2026

SELECT FROM FURNITURE BELOW AND RETURN

Available Furniture for FREE

One (1) of each item per 10' x 10' space.

Booth Size _____ X _____

| Item | Quantity | Price | Total |
|------------------------------------|----------|-----------|-----------|
| 8' x 30"H Table Skirted Show Color | | No Charge | No Charge |
| Side Chair | | No Charge | No Charge |
| Wastebasket | | No Charge | No Charge |

No Package Furniture Needed

No substitutions allowed. Borrowing or trading is NOT allowed.

All additional items in booth will be charged at full price.

For additional items please refer to the appropriate forms.

Orders received after the deadline and onsite orders will be delayed in delivery.

This form is required to be submitted by: Wednesday, August 5, 2026

Submit LVE forms to: exhibitorservices@lvexpo.com / FAX: 702-248-4113

SHOW INFORMATION

We are pleased that LVE has been selected as your Official Service Contractor.
 Our goal is to make sure your participation is a success.

| | | | | |
|---------------------|--|--------------------------|-----------------------|-------------------------------|
| INLINE BOOTH | Each 10' x 10' inline booth will consist of: | | | |
| | BACK WALL DRAPE COLOR | BLACK/TEAL/TEAL/BLACK | SIDE RAIL DRAPE COLOR | BLACK |
| | HALL FLOORING | FACILITY IS NOT CARPETED | | |
| | One | 8' Table Skirted Black | One | Side Chair |
| | One | Wastebasket | One | 11" x 17" Identification Sign |
| | No substitutions allowed. Borrowing or trading is NOT allowed. All additional items in booth will be charged at full price. | | | |

| | | | | |
|---------------------|--|-------------------------|-----|-------------------------------|
| ARTIST BOOTH | Each 5' x 5' inline booth will consist of: | | | |
| | DIVIDERS WILL BE 3' H DRAPE ON ALL SIDES IN SILVER | | | |
| | ARTIST AREA WILL BE CARPETED BLUE | | | |
| | One | 4' Table Skirted Silver | One | Side Chair |
| | One | Wastebasket | One | 11" x 17" Identification Sign |
| | No substitutions allowed. Borrowing or trading is NOT allowed. All additional items in booth will be charged at full price. | | | |

SHOW DATES

| DAY OF WEEK & DATE | START TIME | END TIME | DESCRIPTION |
|--------------------------|------------|----------|----------------------------------|
| Monday, August 24, 2026 | 1:00 PM | 6:00 PM | ONLY Booths 600 sq.ft. or Larger |
| Tuesday, August 25, 2026 | 8:00 AM | 8:00 PM | Exhibitor Setup |

CLEAN FLOOR POLICY WILL BE ENFORCED.

Freight left on the show floor will be removed Tuesday, August 25, 2026.

Empty containers need to be tagged by 7:00 PM Tuesday, August 25, 2026

SHOW READY BY 8:00 PM TUESDAY, AUGUST 25, 2026

***** Small POV move-in only on Wednesday, August 26, 2026 8:00 AM - 10:00 AM *****

| | | | |
|----------------------------|----------|----------|--------------------|
| Wednesday, August 26, 2026 | 11:00 AM | 6:00 PM | Show Hours |
| Thursday, August 27, 2026 | 11:00 AM | 6:00 PM | Show Hours |
| Friday, August 28, 2026 | 11:00 AM | 6:00 PM | Show Hours |
| Friday, August 28, 2026 | 6:00 PM | 11:00 PM | Exhibitor Move Out |
| Saturday, August 29, 2026 | 8:00 AM | 12:00 PM | Exhibitor Move Out |

EARLY TEAR DOWN OF YOUR BOOTH IS NOT PERMITTED.

| | |
|--|--|
| ALL FREIGHT CARRIERS MUST CHECK IN WITH LVE BY: | 9:00 AM on Saturday, August 29, 2026 |
| ALL MHA'S MUST BE COMPLETED AND TURNED IN BY: | 10:00 AM on Saturday, August 29, 2026 |
| ALL FREIGHT MUST BE CLEARED FROM THE FACILITY BY: | 12:00 PM on Saturday, August 29, 2026 |

IMPORTANT: Each exhibitor may begin tear down immediately after the show closes. If you leave the show floor, it is absolutely imperative that you notify LVE Exhibitor Services so that your booth contents will not be disturbed or discarded. LVE will not be held responsible for any booth contents that become missing or damaged during the move out.

CHAMPS LAS VEGAS AUGUST 2026

AUGUST 26 - 28, 2026
LAS VEGAS CONVENTION CENTER - S1 & S2

SHOW INFORMATION CONTINUED

**ALL SHIPMENTS ARE REQUIRED TO HAVE CERTIFIED WEIGHT TICKETS
MATERIAL HANDLING CHARGES APPLY ON ALL SHIPMENTS**

| | | | |
|----------------------------|---|--|--|
| WAREHOUSE SHIPMENTS | WAREHOUSE RECEIVING BEGINS | Monday, July 20, 2026 | WAREHOUSE RECEIVING HOURS MONDAY - FRIDAY 8:00 AM - 3:30 PM EXCLUDING HOLIDAYS |
| | STANDARD RECEIVING RATE DEADLINE | Monday, August 10, 2026 | |
| | WAREHOUSE RECEIVING DEADLINE FOR ON TIME DELIVERY TO THE SHOW | Friday, August 21, 2026 | |
| | All shipments are required to have certified weight tickets | Crated, skidded or boxed materials only | |
| | No COD or collect shipments | Must submit payment authorization form with all orders | |
| | All inbound shipments must be sent to the warehouse | No pad wrapped shipments will be accepted at the warehouse | |

USE THE SHOW SHIPPING LABELS DO NOT SHIP DIRECTLY TO THE FACILITY

| | | | | | |
|----------------------------|--|---|--|---------|--------------|
| WAREHOUSE SHIPMENTS | WAREHOUSE SHIPPING ADDRESS: | SHOW NAME | CHAMPS LAS VEGAS AUGUST 2026 | BOOTH # | |
| | All information must be provided on the shipping labels. Please use the warehouse labels enclosed. | COMPANY | | C/O | LVE-IT VEGAS |
| | | ADDRESS | 6225 Annie Oakley Drive, Las Vegas, NV 89120 | | |
| | | <i>If exhibit material is shipped to the facility, the facility will turn it over to LVE for distribution to your booth. This will result in material handling and late charges from LVE in addition to facility charges.</i> | | | |

**Material Handling rates are round trip rates,
there will be no additional handling fees at the show.**

| | | | | | |
|-----------------------------|--|------------------------------|--|-----|-----|
| SHOWSITE SHIPMENTS | SHOWSITE RECEIVING | | | | |
| | DAY/DATE | START TIME | END TIME | | |
| | Monday, August 24, 2026 | 8:00 AM | 5:00 PM | | |
| | Tuesday, August 25, 2026 | 8:00 AM | 7:00 PM | | |
| | Do not consign shipments to the receiving facility. | | All shipments must be consigned c/o LVE | | |
| | Material shipped direct to the facility will be turned over to LVE and incur additional charges. | | | | |
| | Do not ship your materials to arrive prior to the dates above. | | | | |
| SHOW SITE SHIPPING ADDRESS: | SHOW NAME | CHAMPS LAS VEGAS AUGUST 2026 | BOOTH # | | |
| | All information must be provided on the shipping labels. Please use the show site labels enclosed. | COMPANY | | C/O | LVE |
| | | ADDRESS | LAS VEGAS CONVENTION CENTER - S1 & S2 3150 Paradise Road, Las Vegas, NV 89109 | | |

The Payment Authorization Form must be completed and submitted to LVE prior to shipping.

Note: Shipping to show site may cause a delay in getting your freight to your booth. Receiving is based on the time the driver arrives and the number of deliveries ahead of them. It is advised that you send your shipments in advance to the warehouse to receive them in a timely manner at the show.

BELLMAN

Bellman and the transporting of any and all exhibit materials on a bellman cart will not be allowed. If this method of transporting exhibit materials is used, the exhibitor will be charged the minimum material handling rate of \$175.00 plus applicable fees.

HAND CARRY POLICY

Teamsters Union has jurisdiction over the handling of materials that are transported into and out of the exhibit hall. Exhibitors may transport exhibit materials as long as they adhere to the rules listed on the Hand Carry Policy form included in this manual.

PERSONAL OWNED VEHICLES

Exhibitors may deliver exhibit materials in their personally owned vehicle (POV), as long as they adhere to the rules listed on the Hand Carry Policy form included in this manual.

Submit LVE forms to: exhibitorservices@lvexpo.com / FAX: 702-248-4113

The use of hand carts & dollies is NOT permitted.

Las Vegas Expo has been contracted to assist with all unloading/loading of materials. All loading and unloading must be done in the designated areas.

See Material Handling and Cart Service guidelines within this Exhibitor Service Manual for rates.

Four wheel dollies



Two wheel dollies



Four wheel push carts



HAND CARRY IS LIMITED TO:

This is limited to only ONE exhibitor per booth.

The exhibitor is limited to one trip.

The exhibitor must carry the materials by hand.

All hand carry must be done through the front doors.



HAND CARRY & PERSONAL VEHICLE (POV) GUIDELINES**HAND CARRY POLICY**

Teamsters Union has jurisdiction over the handling of materials that are transported into and out of the exhibit hall.

Exhibitors may hand carry exhibit materials as long as they adhere to the following rules.

- Only one exhibitor per booth may hand carry items.
- The exhibitor must carry the materials by hand.
- The use of wheeled carts or dollies is NOT permitted.
- The exhibitor is limited to one trip.
- The exhibitor must NOT use the loading dock or freight doors for access.

PERSONAL VEHICLE (POV) AND CART SERVICE POLICY & FEES

Exhibitors may deliver exhibit materials in their personally owned vehicle (POV), as long as they meet ALL of the following guidelines. There will be charges for this Round-Trip Service"

- A personal vehicle (POV) is defined as a small passenger car or pick-up.
- You must hire a Teamster and cart to unload vehicle.
- Entire load must weigh less than 200 pounds to qualify for POV fees.
- Entire load must fit on one 2 1/2' x 4' flatbed cart supplied by the Teamster.
- Payment must be provided in advance or at the time of service.

If your material meets ALL of the POV guidelines, the following charges will apply:

- \$ 250.00 - Monday through Friday between 8:00 AM and 4:30 PM, excluding holidays.
- \$ 375.00 - All other times

If you should choose not to wait for a Teamster and cart, but do use the loading dock freight doors, you will still be charged the applicable Material Handling rates for facility access.

If the POV freight is crated, skidded, requires a forklift, or requires more than one trip, Material Handling charges will apply. Please see the Material Handling Form for associated costs.



NOISE ABATEMENT POLICY SOUND RESTRICTIONS

SOUND RESTRICTIONS: Maximum noise level of 85 dB will be maintained on the exhibit floor. This standard is endorsed by the International Association of Expositions and Events (IAEE) and CHAMPS.

CHAMPS noise abatement policy is as follows:

- All booth elements must remain within the officially contracted booth space. This includes all truss work, audio equipment, speakers, etc.
- Exhibitors demonstrating audio equipment in an open display should use a sound chamber or acoustically contained area to keep the sound level from intruding on any adjacent exhibits.
- Speakers of any kind must be directed toward the interior of the exhibitor's booth space. Speakers may not face aisles or neighboring exhibits.
- When demonstrating audio equipment within an enclosed demonstration room, subwoofers must be positioned away from walls that are adjacent to neighboring exhibits.
- Sound complaints will immediately be addressed by CHAMPS Management. If a vibration or sound complaint is not resolved by the offending party, CHAMPS Management reserves the right to shut down power immediately until the issue is resolved.
- Exhibitors are responsible for supervising the actions of employees, visitors or spectators testing display equipment located in their exhibit area

CHAMPS Management will intervene if necessary and reserves the right to shut down exhibits deemed objectionable. Floor managers in each show location will rove through the exhibit areas monitoring the decibel level during show hours. Measurements will be taken at a distance no greater than 10' from the offending display. After measuring a continuous decibel level of greater than 85 dB, following a complaint being registered by a spectator, a neighboring exhibitor or personal observation by a roving designate, the following procedures will be strictly enforced as follows:

First Warning:

- Violating exhibitor will be given a verbal warning
- Booth power may be turned off for one hour

Second Warning:

- Violating exhibitor will be given a verbal 2nd warning
- Booth power may be turned off for one day

HEIGHT REGULATIONS & GUIDELINES LINE OF SIGHT & BOOTH CONSTRUCTION

LINEAR BOOTH

LINEAR BOOTH: Also called “in-line” booths, are generally arranged in a straight line and have neighboring exhibitors on their immediate right and left, leaving only one side exposed to the aisle.

- Hanging signs are not permitted above linear booths.
- Back 5' (1.52m) of booth has a maximum height of 8' (2.44m).
- Front 5' (1.52m) of booth has maximum height restriction of 4' (1.22m) on all materials – structure, product and/or equipment.
- Displays are limited to 4' in height (1.22m), in the front half of each booth. Machinery, equipment or products may not be shown on a raised/built-up platform or counter if they interfere with the height restrictions. If your display exceeds 4' in height (1.22m) it is required that you place it away from the 5' x 10' sightline area in the front of the booth in order to provide a “see-through” lane for neighboring sponsors.
- Inline booths may not exceed 8' in height without written permission.
- Back side of exhibits exceeding 8' in height may NOT display any graphics.
- Unfinished exteriors including video walls must be covered at the exhibitors' expense.

EXAMPLE OF A LINEAR BOOTH:

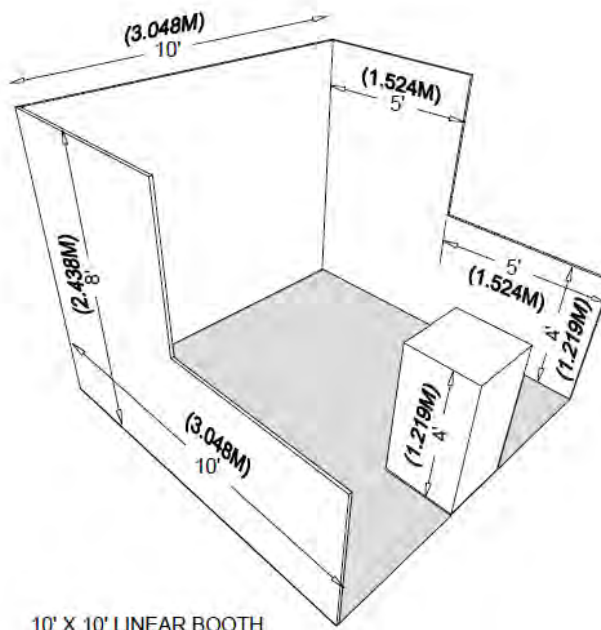

10' X 10' LINEAR BOOTH

HEIGHT REGULATIONS & GUIDELINES BOOTH CONSTRUCTION REGULATIONS & DIAGRAMS

PENINSULA BOOTH

PENINSULA BOOTH: Exhibit which occupies both corners at the end of a row of standard linear booths with an aisle on three sides. A peninsula booth is a minimum of 20' x 20' (6.096m x 6.096m) in size.

- Maximum height of 16' (4.88m), or higher with Event Management approval.
- If you have a hanging sign, there must be at least 3' (0.9144m) clearance from the top of the booth to the bottom of the sign and the total booth presence cannot exceed 20' (6.096m).
- All display fixtures over 4' (1.22m) in height and placed within 10' (3.05m) of a neighboring exhibit must be confined to that area of the booth that is at least 5' (1.52m) from the aisle line to avoid blocking the sight line from the aisle to the adjoining booth.
- Peninsula booths are 'faced' towards the cross aisle. Any portion of the booth bordering another exhibitor's booth must have a finished back side and must not carry identification signs or other copy that would detract from the adjoining exhibit.
- Please bring all US Engineer-stamped, approved plans onsite for the Fire Marshal. The Fire Marshal reserves the right to deny booth construction without these plans.
- Walls must be finished on both sides so as not to be unsightly to neighboring exhibitors.
- Unfinished exteriors including video walls must be covered at the exhibitors' expense.

EXAMPLE OF A PENINSULA BOOTH:

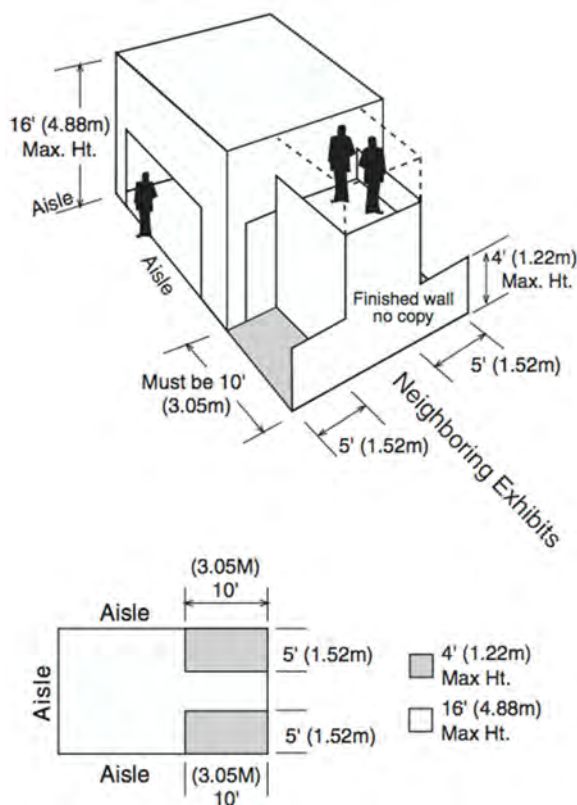



HEIGHT REGULATIONS & GUIDELINES
LINE OF SIGHT & BOOTH CONSTRUCTION

ISLAND BOOTH

ISLAND BOOTH: A minimum of four standard booths (**20' x 20' / 6 meters x 6 meters or larger**), exposed to aisles on all four sides.

- The maximum height is 16' (4.88 meters). Maximum booth presence (including top of hanging signs) can be 20' with show management pre-approval.
- If you have a hanging sign, there must be at least a 3' clearance from the highest point of the booth properties to the bottom of the sign. Total height to top of sign cannot be higher than 20'.
- The length of any solid perimeter wall, structure, video wall, or combination of elements exceeding 8' in height (2.4384m) from the ground located within 3' from any adjoining aisle is limited to half the length (or width) of your contracted space.
- Walls must be finished on both sides so as not to be unsightly to neighboring exhibitors.
- Unfinished exteriors including video walls must be covered at the exhibitors' expense.
- Exhibitors may use Plexiglas or similar see-through material to create a wall that will allow for a line of sight from one booth to the next.
- If you have any type of interactive display, you must have a 3' clearance from the aisle(s) to allow for crowds.
- All exhibitors must bring a copy of their US Engineer-stamped plans on-site for the Fire Marshal. The Fire Marshal reserves the right to deny booth construction without these plans.

WELCOME LETTER

Dear Exhibitor,

LVE is pleased to have been selected by Show Management as your Official Service Contractor to ensure that your show participation is successful.

The exhibitor manual contains IMPORTANT information and order forms on the wide variety of services offered. Please review this manual carefully to determine which products and services will be necessary for your exhibit. Be sure to return the completed forms promptly to take advantage of discount pricing. You may receive substantial discounts on many decorating items and services on orders placed by the discount deadline dates. Please see order forms for applicable deadline dates.

LVE requires payment in full at the time services are requested. Purchase Orders are not considered advance payment. Payments may be made by wire transfer or credit/debit cards. VISA, Discover, MasterCard, and American Express are accepted. A credit card authorization form is enclosed for your convenience as a credit/debit card on file is required. The card will be used for all services provided at this show and for any outstanding balances. All materials are on a rental basis only and remain the property of LVE.

It is our mission to provide you with a seamless planning process, a supporting infrastructure, and to be a reliable information resource that will result in the successful execution of your event. Our Exhibitor Services department is available to assist you with all of your needs, including any questions you may have prior to, during, and post show. You may reach us at 888-989-3976 during the hours of 7:30 am - 4:00 pm (PST) Monday through Friday, or email us at exhibitorservices@lvexpo.com. You can also visit our Exhibitor Services Desk at show site.

We look forward to serving you!

Sincerely,
LVE



CHAMPS LAS VEGAS AUGUST 2026

AUGUST 26 - 28, 2026

LAS VEGAS CONVENTION CENTER - S1 & S2

PAYMENT AUTHORIZATION

Please complete the information requested and return payment in full with your order forms. Purchase Orders are not considered advance payment. You may choose to pay by credit card, wire transfer or money order; however, we require that your credit card information remain on file with LVE. Any additional balances or charges for outbound freight, labor or miscellaneous items not paid, will be charged to your credit card account where applicable. Discount pricing applies only to orders received with full payment prior to the deadline date. **Please note: By utilizing this form, exhibitors acknowledge that they have read and agree to comply with the terms of the Payment Options & Policy and Terms and Conditions statements contained herein. CONVENIENCE FEE - All orders paid with a credit card will incur an additional non-refundable 3% fee.**

| | | | | | | |
|----------------|--------------|--|-------|-------------|---------|-------|
| CONTACT | COMPANY NAME | | | CLIENT NAME | | |
| | ADDRESS | | | | BOOTH # | |
| | CITY | | STATE | ZIP | | PHONE |
| | EMAIL | | | | FAX | |

| | | | | | | | | |
|----------------------------------|---|--|-------------------------------|--|-------------------------------------|--|---|--|
| CREDIT CARD AUTHORIZATION | <input type="checkbox"/> DISCOVER | | <input type="checkbox"/> VISA | | <input type="checkbox"/> MASTERCARD | | <input type="checkbox"/> AMERICAN EXPRESS | |
| | ACCOUNT NUMBER | | | | | | | |
| | EXPIRATION DATE | | | | SECURITY CODE REQUIRED | | | |
| | <i>The security code can be found on the front of your Amex or on back of your Visa, Discover and MasterCard.</i> | | | | | | | |
| | CARDHOLDER'S BILLING ADDRESS (IF DIFFERENT FROM ABOVE) | | | | | | | |
| | CITY | | STATE | | ZIP | | | |
| | CARDHOLDER'S SIGNATURE* | | X _____ | | | | | |
| | CARDHOLDER'S NAME (PLEASE PRINT) | | | | | | | |

*By signing, I agree to the Terms and Conditions located on www.lvexpo.com as well as contained within this manual.
Cancellation Policy varies per service as noted on each form.
All credit card information will be kept on file to be used for future shows and all outstanding balances.
Signer authorizes agent/employees to sign off and create order for the company.

| | | | | |
|--------------------|----------------|----------------|--|-----------------------------|
| ORDER RECAP | DISCOUNT PRICE | STANDARD PRICE | ONSITE PRICE | SERVICE |
| | | | | FURNITURE & ACCESSORIES |
| | | | | CARPET |
| | | | | SIGNS |
| | | | | CLEANING |
| | | | | LABOR |
| | | | | ESTIMATED MATERIAL HANDLING |
| | | | | PACKAGE RENTAL BOOTH |
| | | | | OTHER EXPO SERVICES |
| | | | | TAX |
| TOTAL | TOTAL | TOTAL | CONVENIENCE FEE - All orders paid with a credit card will incur an additional non-refundable 3% fee. | |

Be advised, if a valid credit card is not provided prior to the shipment of your freight or ordering services, the card on file from the previous show will be charged. If you require us to change your form of payment and process a credit once the charge has processed there will be a \$75.00 processing fee. To avoid this charge, it is your responsibility to ensure that there is a valid card on file before submitting orders or shipping freight.

Damage to rental items outside of normal wear and tear could result in exhibitor charges for replacement. If you suspect you have potential errors on your charge card you have 60 days after the error appeared on your statement to contact us. You must notify us of the potential errors in writing.

Submit LVE forms to: exhibitorservices@lvexpo.com / FAX: 702-248-4113

CHAMPS LAS VEGAS AUGUST 2026

AUGUST 26 - 28, 2026
LAS VEGAS CONVENTION CENTER - S1 & S2

| | | | |
|---------------------|--|----------------|--|
| COMPANY NAME | | BOOTH # | |
|---------------------|--|----------------|--|

FURNITURE

ORDER ONLINE
order.lvexpo.com

| | QTY | DISCOUNT RECEIVED BY | STANDARD BEGINS | ONSITE BEGINS | TOTAL |
|-----------------------|-------------------------------------|----------------------|-----------------|---------------|-------|
| | | 8/5/2026 | 8/6/2026 | 8/20/2026 | |
| CHAIRS | SIDE CHAIR | \$ 126.00 | \$ 176.40 | \$ 201.60 | |
| | ARM CHAIR | \$ 157.50 | \$ 220.50 | \$ 252.00 | |
| | STOOL COUNTER HEIGHT | \$ 204.75 | \$ 286.65 | \$ 327.60 | |
| TABLES | 4'L x 30"H x 24"W TABLE SKIRTED* | \$ 173.25 | \$ 242.55 | \$ 277.20 | |
| | 6'L x 30"H x 24"W TABLE SKIRTED* | \$ 199.50 | \$ 279.30 | \$ 319.20 | |
| | 8'L x 30"H x 24"W TABLE SKIRTED* | \$ 235.20 | \$ 329.28 | \$ 376.32 | |
| | 4'L x 30"H x 24"W TABLE UNSKIRTED | \$ 115.50 | \$ 161.70 | \$ 184.80 | |
| | 6'L x 30"H x 24"W TABLE UNSKIRTED | \$ 134.40 | \$ 188.16 | \$ 215.04 | |
| | 8'L x 30"H x 24"W TABLE UNSKIRTED | \$ 157.50 | \$ 220.50 | \$ 252.00 | |
| COUNTER TABLES | 4'L x 42"H x 24"W COUNTER SKIRTED* | \$ 204.75 | \$ 286.65 | \$ 327.60 | |
| | 6'L x 42"H x 24"W COUNTER SKIRTED* | \$ 231.00 | \$ 323.40 | \$ 369.60 | |
| | 8'L x 42"H x 24"W COUNTER SKIRTED* | \$ 264.60 | \$ 370.44 | \$ 423.36 | |
| | 4'L x 42"H x 24"W COUNTER UNSKIRTED | \$ 147.00 | \$ 205.80 | \$ 235.20 | |
| | 6'L x 42"H x 24"W COUNTER UNSKIRTED | \$ 171.15 | \$ 239.61 | \$ 273.84 | |
| | 8'L x 42"H x 24"W COUNTER UNSKIRTED | \$ 199.50 | \$ 279.30 | \$ 319.20 | |
| CAFÉ | TABLE ROUND 36"W x 30"H | \$ 231.00 | \$ 323.40 | \$ 369.60 | |
| | TABLE ROUND 36"W x 42"H | \$ 267.75 | \$ 374.85 | \$ 428.40 | |
| ACCESSORIES | 4th SIDE TABLE SKIRT* | \$ 92.40 | \$ 129.36 | \$ 147.84 | |
| | 4th SIDE COUNTER SKIRT* | \$ 102.90 | \$ 144.06 | \$ 164.64 | |
| | RISER FOR TABLE TOP 4'L x 14"H | \$ 136.50 | \$ 177.45 | \$ 218.40 | |
| | RISER FOR TABLE TOP 6'L x 14"H | \$ 178.50 | \$ 232.05 | \$ 285.60 | |

*SELECT SKIRT COLOR - If no skirt color is selected the designated show color will be provided.

| | | | | | |
|--------------|---------------------------------|-----------------------------------|-------------------------------|-------------------------------------|--------------------------------|
| COLOR | <input type="checkbox"/> Green | <input type="checkbox"/> Teal | <input type="checkbox"/> Red | <input type="checkbox"/> Royal Blue | <input type="checkbox"/> Black |
| | <input type="checkbox"/> Silver | <input type="checkbox"/> Burgundy | <input type="checkbox"/> Gold | <input type="checkbox"/> White | <input type="checkbox"/> Beige |

CANCELLATION POLICY

The Payment Authorization Form must be submitted with this order.

Damage to rental items outside of normal wear and tear could result in exhibitor charges for replacement.

Items cancelled after the discount deadline date will be charged at 50% of ordered price.

No credit will be given after close of event on items or services ordered but not received.

CHAMPS LAS VEGAS AUGUST 2026

AUGUST 26 - 28, 2026

LAS VEGAS CONVENTION CENTER - S1 & S2

| | | | | | |
|--------------|--|---------|--|---------|--|
| COMPANY NAME | | BOOTH # | | BOOTH # | |
|--------------|--|---------|--|---------|--|

ACCESSORIES

| <div style="border: 2px solid black; border-radius: 50%; padding: 10px; display: inline-block;"> ORDER ONLINE order.lvexpo.com </div> | | QTY | DISCOUNT RECEIVED BY | STANDARD BEGINS | ONSITE BEGINS | TOTAL |
|--|---|-----|----------------------|-----------------|---------------|-------|
| | | | 8/5/2026 | 8/6/2026 | 8/20/2026 | |
| ACCESSORIES | WASTEBASKET | | \$ 33.08 | \$ 46.31 | \$ 52.92 | |
| | EASEL | | \$ 72.45 | \$ 100.80 | \$ 115.92 | |
| | BAG RACK | | \$ 136.50 | \$ 191.10 | \$ 218.40 | |
| | GARMENT RACK | | \$ 183.75 | \$ 257.25 | \$ 294.00 | |
| | WATERFALL CLOTHING RACK 4 - ARM | | \$ 121.95 | \$ 158.55 | \$ 195.13 | |
| | LITERATURE RACK (FREE STANDING) | | \$ 172.67 | \$ 241.74 | \$ 276.28 | |
| | SIGN HOLDER 22" x 28" | | \$ 112.90 | \$ 158.07 | \$ 180.65 | |
| | TACKBOARD 4' x 6' VERTICAL | | \$ 241.50 | \$ 326.00 | \$ 386.40 | |
| | TACKBOARD 6' x 4' HORIZONTAL | | \$ 241.50 | \$ 326.00 | \$ 386.40 | |
| | GRID 2' x 8' | | \$ 257.25 | \$ 360.15 | \$ 411.60 | |
| | GRID 2' x 8' WITH LEGS | | \$ 299.25 | \$ 418.95 | \$ 478.80 | |
| | 18" WATERFALL ARM FOR GRID | | \$ 54.60 | \$ 70.98 | \$ 87.36 | |
| | GRID HOOKS (CHOOSE SIZE BELOW) <input type="checkbox"/> 2" <input type="checkbox"/> 6" <input type="checkbox"/> 8" | | \$ 12.60 | \$ 17.64 | \$ 20.16 | |

| | | | | | |
|--|----|----------|-----------|-----------|--|
| 8' HIGH DRAPE* PER LN. FT. AT 10' INCREMENTS | FT | \$ 23.10 | \$ 32.34 | \$ 36.96 | |
| 8' UPRIGHT POLE W/BASE (NO DRAPE) | | \$ 42.00 | \$ 56.70 | \$ 67.20 | |
| 12' - 16' UPRIGHT POLE W/BASE (NO DRAPE) | | \$ 78.75 | \$ 106.31 | \$ 115.00 | |
| 6' - 10' TELESCOPIC ROD (NO DRAPE) | | \$ 31.40 | \$ 42.39 | \$ 50.23 | |
| ZIP STANCHIONS (TENZA BARRIERS) Min. Order 2 | | \$ 99.75 | \$ 129.78 | \$ 150.50 | |

*SELECT DRAPE COLOR - If no drape color is selected, the designated show color will be provided.

Silver
 Black
 White

CANCELLATION POLICY

The Payment Authorization Form must be submitted with this order.

Damage to rental items outside of normal wear and tear could result in exhibitor charges for replacement.

Items cancelled after the discount deadline date will be charged at 50% of ordered price.

No credit will be given after close of event on items or services ordered but not received.

CHAMPS LAS VEGAS AUGUST 2026

AUGUST 26 - 28, 2026

LAS VEGAS CONVENTION CENTER - S1 & S2

| | | | |
|--------------|--|---------|--|
| COMPANY NAME | | BOOTH # | |
|--------------|--|---------|--|

SHELVING UNITS

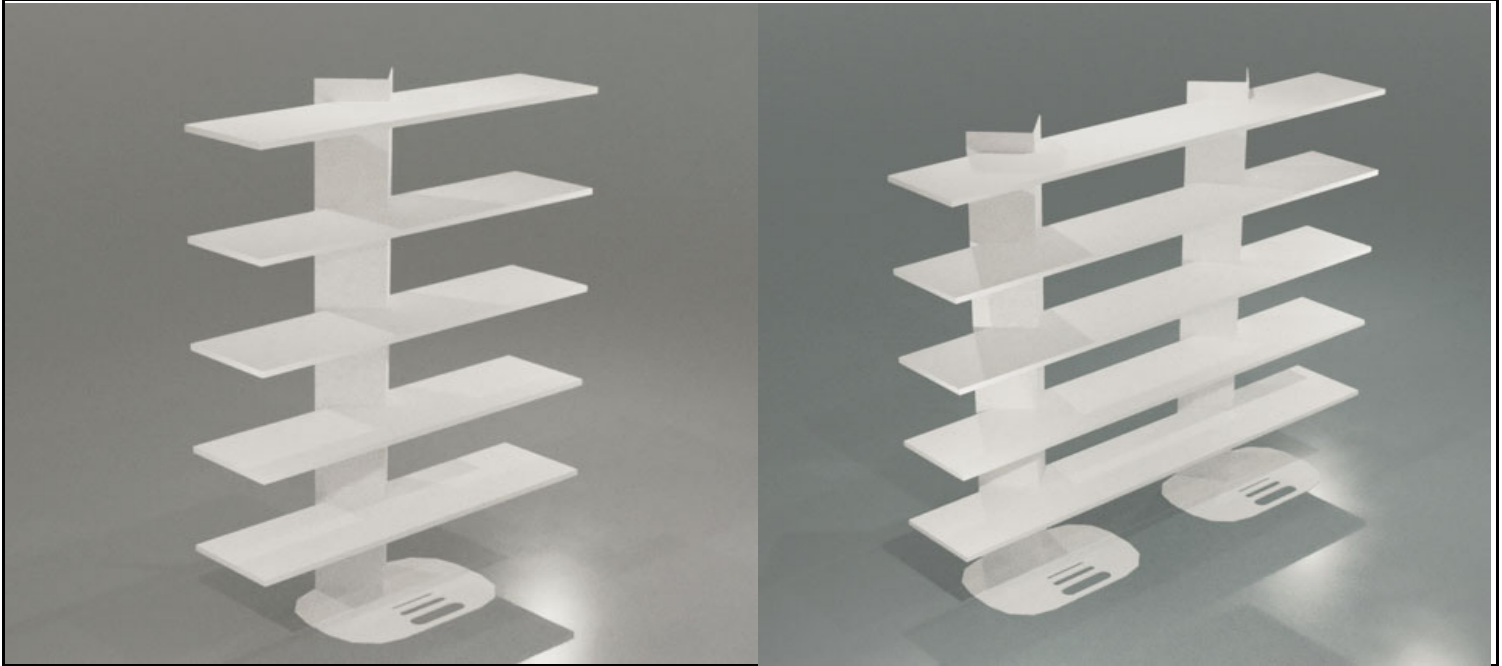
 DEADLINE DATE: **8/5/2026**

SINGLE SHELVING UNIT

DOUBLE SHELVING UNIT

| | | | |
|-----------------------|------------------|-----------------------|------------------|
| DISCOUNT PRICE | \$ 269.60 | DISCOUNT PRICE | \$ 475.00 |
| STANDARD PRICE | \$ 398.96 | STANDARD PRICE | \$ 641.25 |
| ONSITE PRICE | \$ 491.36 | ONSITE PRICE | \$ 760.00 |

| | |
|------------------------------------|---------------------------------|
| SINGLE SHELVING UNIT SPECS: | UNIT: 48"W x 62 7/8"H |
| | SHELVES: (4) 48"W x 12"D |
| DOUBLE SHELVING UNIT SPECS: | UNIT: 72"W x 62 7/8"H |
| | SHELVES: (4) 72"W x 12"D |

| SHELVING | | QUANTITY | DISCOUNT RECEIVED BY | STANDARD BEGINS | ONSITE BEGINS | TOTAL |
|-----------------|--------------------|-----------------|-----------------------------|------------------------|----------------------|--------------|
| | | | 8/5/2026 | 8/6/2026 | 8/20/2026 | |
| | SINGLE UNIT | | \$ 269.60 | \$ 398.96 | \$ 491.36 | |
| | DOUBLE UNIT | | \$ 475.00 | \$ 641.25 | \$ 760.00 | |

CANCELLATION POLICY

Items cancelled after the discount deadline date will be charged at 50% of ordered price.

Items cancelled after show move-in begins will be charged 100% of the original price.

All materials are to remain the property of LVE.

CHAMPS LAS VEGAS AUGUST 2026

AUGUST 26 - 28, 2026

LAS VEGAS CONVENTION CENTER - S1 & S2

| | | | |
|--------------|--|---------|--|
| COMPANY NAME | | BOOTH # | |
|--------------|--|---------|--|

SHOWCASES



FULL

HALF

QUARTER

TOWER

WALL CASE

SEE-THROUGH
WALL CASE

ALL UNITS COME STANDARD WITH FLORESCENT LIGHTING, ELECTRICAL OUTLET IS NOT INCLUDED
AVAILABILITY ONSITE IS LIMITED

We reserve the right to substitute items of similar quality and value if necessary.

| | | | | | |
|---|-----|-------------------------|--------------------|---------------------|--------------|
| ORDER ONLINE online.lvexpo.com | QTY | DISCOUNT | STANDARD | ONSITE | TOTAL |
| | | RECEIVED BY 8/5/2026 | BEGINS 8/6/2026 | BEGINS 8/20/2026 | |

| | | | | | |
|--|--|-------------|-------------|-------------|--|
| SHOWCASES | FULL VIEW (ONLY AVAILABLE IN WHITE) 4' Wide | \$ 777.29 | \$ 1,154.28 | \$ 1,368.03 | |
| | FULL VIEW (ONLY AVAILABLE IN WHITE) 5' Wide | \$ 857.65 | \$ 1,273.60 | \$ 1,509.46 | |
| | FULL VIEW (ONLY AVAILABLE IN WHITE) 6' Wide | \$ 938.01 | \$ 1,392.95 | \$ 1,650.90 | |
| | 4' Wide - WHITE Select View: HALF OR QUARTER | \$ 777.29 | \$ 1,154.28 | \$ 1,368.03 | |
| | 4' Wide - BLACK Select View: HALF OR QUARTER | \$ 859.11 | \$ 1,275.78 | \$ 1,512.04 | |
| | 5' Wide - WHITE Select View: HALF OR QUARTER | \$ 857.65 | \$ 1,273.60 | \$ 1,509.46 | |
| | 5' Wide - BLACK Select View: HALF OR QUARTER | \$ 939.47 | \$ 1,395.11 | \$ 1,653.46 | |
| | 6' Wide - WHITE Select View: HALF OR QUARTER | \$ 938.01 | \$ 1,392.95 | \$ 1,650.90 | |
| | 6' Wide - BLACK Select View: HALF OR QUARTER | \$ 1,019.83 | \$ 1,514.45 | \$ 1,794.90 | |
| | TOWER 80"H x 20"W x 20"D - WHITE | \$ 803.59 | \$ 1,193.33 | \$ 1,414.32 | |
| | TOWER 80"H x 20"W x 20"D - BLACK | \$ 900.02 | \$ 1,336.53 | \$ 1,584.04 | |
| | WALL CASE 48" W x 84" H x 18" D - WHITE | \$ 1,326.66 | \$ 1,970.08 | \$ 2,334.91 | |
| | WALL CASE 48" W x 84" H x 18" D - BLACK | \$ 1,423.09 | \$ 2,113.28 | \$ 2,504.63 | |
| | WALL CASE 60" W x 84" H x 18" D - WHITE | \$ 1,407.02 | \$ 2,089.43 | \$ 2,476.36 | |
| | WALL CASE 60" W x 84" H x 18" D - BLACK | \$ 1,503.45 | \$ 2,232.63 | \$ 2,646.08 | |
| | WALL CASE 70" W x 84" H x 18" D - WHITE | \$ 1,487.37 | \$ 2,208.75 | \$ 2,617.78 | |
| | WALL CASE 70" W x 84" H x 18" D - BLACK | \$ 1,583.04 | \$ 2,350.82 | \$ 2,786.16 | |
| | SEE-THROUGH WALL CASE 70" W x 84" H x 18"D WHITE | \$ 1,347.11 | \$ 2,000.46 | \$ 2,370.92 | |
| SEE-THROUGH WALL CASE 70" W x 84" H x 18"D BLACK | \$ 1,443.54 | \$ 2,143.66 | \$ 2,540.63 | | |
| UPGRADED LED LIGHTING | \$ 176.78 | \$ 262.52 | \$ 311.14 | | |

CANCELLATION POLICY

*The Payment Authorization Form must be submitted with this order.
Cancellations after the discount deadline date will be charged at 50% of ordered price.
No credit will be given after move-in begins.*

CHAMPS LAS VEGAS AUGUST 2026

AUGUST 26 - 28, 2026
LAS VEGAS CONVENTION CENTER - S1 & S2

COMPANY NAME

BOOTH #

CARPET

| | CARPET LENGTH | QTY | DISCOUNT RECEIVED BY | | STANDARD BEGINS | ONSITE BEGINS | TOTAL | | |
|---|---|----------|----------------------|-------------|-----------------|---------------|----------|-------|--|
| | | | 8/5/2026 | | 8/6/2026 | 8/20/2026 | | | |
| STANDARD | 10' x 10' | | \$ 325.50 | \$ 455.70 | \$ 625.80 | | | | |
| | 10' x 20' | | \$ 651.00 | \$ 911.40 | \$ 1,041.60 | | | | |
| | 10' x 30' | | \$ 976.50 | \$ 1,367.10 | \$ 1,562.40 | | | | |
| | CUSTOM SIZES - 100 sqft increments For sizes over 300 sqft you will be charged custom price. | | LENGTH | | WIDTH | TOTAL SQ FT | | | |
| | | DISCOUNT | \$ 4.47 | STANDARD | \$ 6.25 | ONSITE | \$ 7.14 | TOTAL | |
| <input type="checkbox"/> Red <input type="checkbox"/> Blue <input type="checkbox"/> Black <input type="checkbox"/> Gray <input type="checkbox"/> Burgundy | | | | | | | | | |
| <i>If you order carpet but no color is selected above, black carpet will be installed. Orders of multiple runs of carpet do not include seaming and exact color match is not guaranteed.</i> | | | | | | | | | |
| PLUSH | 10' x 10' | | \$ 735.00 | \$ 1,029.00 | \$ 1,176.00 | | | | |
| | 10' x 20' | | \$ 1,470.00 | \$ 2,058.00 | \$ 2,352.00 | | | | |
| | 10' x 30' | | \$ 2,205.00 | \$ 3,087.00 | \$ 3,528.00 | | | | |
| | CUSTOM SIZES - 100 sqft increments For sizes over 300 sqft you will be charged custom price. | | LENGTH | | WIDTH | TOTAL SQ FT | | | |
| | | DISCOUNT | \$ 9.20 | STANDARD | \$ 12.87 | ONSITE | \$ 14.70 | TOTAL | |
| ULTRA PLUSH | 10' x 10' | | \$ 997.50 | \$ 1,396.50 | \$ 1,596.00 | | | | |
| | 10' x 20' | | \$ 1,995.00 | \$ 2,793.00 | \$ 3,192.00 | | | | |
| | 10' x 30' | | \$ 2,992.50 | \$ 4,189.50 | \$ 4,788.00 | | | | |
| | CUSTOM SIZES - 100 sqft increments For sizes over 300 sqft you will be charged custom price. | | LENGTH | | WIDTH | TOTAL SQ FT | | | |
| | | DISCOUNT | \$ 12.08 | STANDARD | \$ 16.90 | ONSITE | \$ 19.32 | TOTAL | |
| CIRCLE COLOR OPTION FOR PLUSH & ULTRA PLUSH CARPET (COLOR SAMPLES ON FOLLOWING PAGE) | | | | | | | | | |
| Fire Red Lime Magenta Purple Orange Sunshine Forest Process Blue Black Bright Blue Khaki Cream Snowflake Silvermoon Aluminum Shadow Slate English Gray | | | | | | | | | |
| ACCESSORIES | PADDING PER SQ FT* | | \$ 2.05 | \$ 2.87 | \$ 3.28 | | | | |
| | VISQUEEN PER SQ FT* | | \$ 1.42 | \$ 1.98 | \$ 2.27 | | | | |
| | DOUBLE PADDING PER SQ FT* | | \$ 4.10 | \$ 5.73 | \$ 6.55 | | | | |

* 100 Square Feet Minimum Order

CANCELLATION POLICY

Items cancelled after the discount deadline date will be charged 50% of ordered price.

Items cancelled after show move-in begins will be charged 100% of ordered price.

Damage to rental items outside of normal wear and tear could result in exhibitor charges for replacement.

No refunds on custom or plush carpet orders. No credit will be given after close of event on anything ordered but not received.

Submit LVE forms to: exhibitorservices@lvexpo.com / FAX: 702-248-4113

| | | | |
|---------------------|--|----------------|--|
| COMPANY NAME | | BOOTH # | |
|---------------------|--|----------------|--|

CUSTOM CARPET COLORS
COLORS AVAILABLE FOR PLUSH AND ULTRA PLUSH

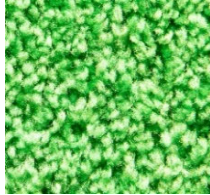
RED FIRE

LIME

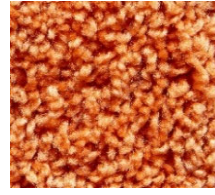
MAGENTA

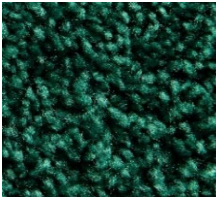
PURPLE

ORANGE

SUNSHINE

FOREST

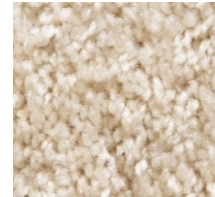
PROCESS BLUE

BRIGHT BLUE

KHAKI

CREAM

SNOWFLAKE

SILVERMOON

ALUMINUM

SHADOW

SLATE

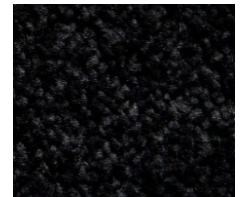
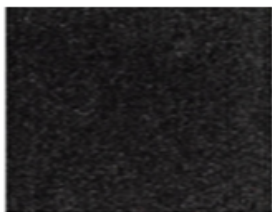
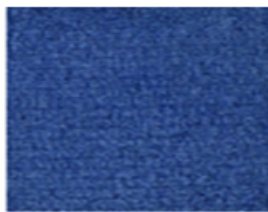
ENGLISH GRAY

BLACK
STANDARD CARPET COLORS

BLACK

BLUE

BURGUNDY

GRAY

RED

CHAMPS LAS VEGAS AUGUST 2026

AUGUST 26 - 28, 2026

LAS VEGAS CONVENTION CENTER - S1 & S2

COMPANY NAME _____

BOOTH # _____

BOOTH CLEANING & PORTER SERVICE

BOOTH CLEANING

| AVAILABLE SERVICES (Minimum 100 sq.ft.) | DISCOUNT RECEIVED BY | STANDARD BEGINS | ONSITE BEGINS | TOTAL BOOTH SQ FT* Rates Per Sq. Ft. (Minimum 100 sq.ft.) | TOTAL |
|---|---|-----------------|---------------|---|----------------------|
| | 8/5/2026 | 8/6/2026 | 8/20/2026 | | |
| VACUUMING | ONE TIME VACUUMING PRIOR TO SHOW OPEN | \$ 1.26 | \$ 1.64 | \$ 2.02 | X _____ * = _____ ** |
| | DAILY VACUUMING PRIOR TO EACH SHOW DAY | \$ 3.09 | \$ 4.02 | \$ 4.95 | X _____ * = _____ ** |
| *How to Calculate Booth Sq Ft? Length _____ X Width _____ = Total Booth Sq Ft _____ | | | | | |
| **How to Calculate Total? Total Booth Sq Ft _____ x Rate _____ = Total _____ | | | | | |

PORTER SERVICE ORDER

Porter Service does NOT include vacuuming.

| PORTER SERVICE RATES ARE PER SHOW DAYS | SELECT BOOTH SIZE | SHOW DAYS | DISCOUNT RECEIVED BY | STANDARD BEGINS | ONSITE BEGINS | TOTAL |
|---|-------------------|-----------|----------------------|------------------|-------------------|-------|
| | | | 8/5/2026 | 8/6/2026 | 8/20/2026 | |
| Up to 1,000 square feet | | 3 | \$ 325.50 per day | \$423.15 per day | \$ 520.80 per day | |
| 1,001 to 3,000 square feet | | 3 | \$ 388.50 per day | \$505.05 per day | \$ 621.60 per day | |
| 3,001 and above | | 3 | \$ 567.00 per day | \$737.10 per day | \$ 907.20 per day | |

How to Calculate Porter Service? # of Show Days _____ X Rate _____ = Total _____

Includes emptying of wastebaskets in your exhibit area in two hour intervals during show hours.

Porter Service does NOT include wiping down of booth.

Please bring cleaning concerns to our attention onsite.
LVE will be unable to address the concern after the close of the show.

ADDITIONAL CHARGES WILL APPLY FOR THE FOLLOWING:

- Removal of excessive items left in booth at the close of show will be charged per man hour to remove and possible dumpster fees.
- Removal of adhesive materials or stickers on the show floor will be billed per man hour for removal.

CANCELLATION POLICY

Services cancelled after the discount deadline date will be charged 50% of ordered price.

Services cancelled after show move-in begins will be charged 100% of ordered price.

No credit will be given after close of event on anything ordered but not received.

CHAMPS LAS VEGAS AUGUST 2026

AUGUST 26 - 28, 2026
LAS VEGAS CONVENTION CENTER - S1 & S2

| | | | |
|--------------|--|---------|--|
| COMPANY NAME | | BOOTH # | |
|--------------|--|---------|--|

GRAPHICS & SIGNS

DISCOUNT DEADLINE: 8/5/2026

LVE has the capabilities to provide you with the finest digital graphic reproduction available. Capabilities including four-color, photo-quality, high-resolution digital printing of virtually any size for banners, signage, exhibit graphics on a variety of substrates.

| STANDARD SIZES | STANDARD GRAPHIC SIZES | QTY | DISCOUNT RECEIVED BY 8/5/2026 | STANDARD BEGINS 8/6/2026 | ONSITE BEGINS 8/20/2026 | TOTAL |
|--|--------------------------------|-----------|----------------------------------|-----------------------------|----------------------------|-------|
| | <i>Single-sided printing</i> | | | | | |
| | FOMECOR w/Easel Back 12" x 18" | | \$ 94.50 | \$ 132.30 | \$ 151.20 | |
| | FOMECOR SIGN 22" x 28" | | \$ 109.20 | \$ 152.88 | \$ 174.72 | |
| | FOMECOR SIGN 24" x 36" | | \$ 151.20 | \$ 211.68 | \$ 241.92 | |
| | FOMECOR SIGN 28" x 44" | | \$ 216.30 | \$ 302.82 | \$ 346.08 | |
| FOMECOR SIGN w/Base 38" x 87" | | \$ 577.50 | \$ 808.50 | \$ 924.00 | | |
| <i>All prices listed above are on 3/16" FOMECOR</i> | | | | | | |
| <i>File conversion, retouching, cloning or color correcting may incur additional labor charges. Print ready graphics are required. Artwork must match the size requested. See Graphic Submission</i> | | | | | | |

| DIGITAL GRAPHICS PRICE PER SQUARE FOOT | MATERIAL (Per s/f) | DISCOUNT | STANDARD | ONSITE | MATERIAL | DISCOUNT | STANDARD | ONSITE |
|--|--------------------|----------|----------|-----------|--------------|----------|----------|----------|
| | 1/4" PLEXIGLAS | \$ 63.00 | \$ 75.60 | \$ 100.80 | 3mm PVC | \$ 29.40 | \$ 37.80 | \$ 47.04 |
| | 3/16" FOMECOR | \$ 27.30 | \$ 35.70 | \$ 43.68 | 6mm PVC | \$ 33.60 | \$ 42.00 | \$ 53.76 |
| | VINYL BANNER | \$ 21.00 | \$ 29.40 | \$ 42.00 | FLOOR DECALS | \$ 37.80 | \$ 46.20 | \$ 60.48 |

PLEASE CONTACT OUR GRAPHIC DEPARTMENT FOR PRICE QUOTES ON GRAPHICS OVER 80 sq. Ft.

| | | |
|----------------------|--|---|
| ELECTRONIC FILE NAME | | MATERIAL (Choose Below) |
| PMS COLOR | | <input type="checkbox"/> FOMECOR <input type="checkbox"/> PVC <input type="checkbox"/> PLEXI <input type="checkbox"/> GATORFOAM |
| APPLICATION | | <input type="checkbox"/> ECO-BOARD* <input type="checkbox"/> ULTRA-BOARD* <input type="checkbox"/> OTHER |

**The product offered has recycled content or has eco-friendly attributes and is 100% recyclable according to the manufacturer's specifications.*

| | | | | | | | | | | | | | |
|--|--|----------|-----|--|---------|--|---------|---------|--|----------|--|--|--|
| SPECIAL INSTRUCTIONS | | | | | | | | | | | | | |
| Minimum order \$75.00 Double sq. Ft. for double-sided graphics Round sq. Ft. to next whole increment File conversion, retouching, cloning or color correcting may incur additional labor charges. | <table style="margin: auto;"> <tr> <td style="border: 1px solid black; width: 50px; height: 20px;"></td> <td style="padding: 0 5px;">L X</td> <td style="border: 1px solid black; width: 50px; height: 20px;"></td> <td style="padding: 0 5px;">W =</td> <td style="border: 1px solid black; width: 50px; height: 20px;"></td> <td style="padding: 0 5px;">sq. Ft.</td> </tr> <tr> <td style="padding: 0 5px;">sq. Ft.</td> <td style="padding: 0 5px;"></td> <td style="padding: 0 5px;">X RATE =</td> <td style="padding: 0 5px;"></td> <td style="padding: 0 5px;"></td> <td style="padding: 0 5px;"></td> </tr> </table> | | L X | | W = | | sq. Ft. | sq. Ft. | | X RATE = | | | |
| | L X | | W = | | sq. Ft. | | | | | | | | |
| sq. Ft. | | X RATE = | | | | | | | | | | | |

SEE ARTWORK SUBMISSION REQUIREMENTS

It is our goal to provide our customers with accurate, high-quality graphics and trade show signs. In order to achieve this goal, all artwork submitted to us for production must meet ALL of the requirements listed. Please send any questions or concerns to: exhibitorservices@lvexpo.com

IMPORTANT! - Please be 100% sure to convert ALL FONTS to OUTLINES! Do not send us font files to replace missing text.

LVE will not offer any refunds on graphics that have been produced.



Las Vegas Expo has the capability to print digital graphics for any need. Our skilled associates will work with you to ensure the highest quality output when the job is printed. We have worked with many different types of media on an assortment of unique equipment. The end result: attractive, attention-grabbing displays and signage that are sure to start conversations.

LVE Show Graphic, our state-of-the-art graphics department, brings both vast industry knowledge and unmatched production capabilities to the table. We believe that presentation is everything. The importance of vivid eye-catching graphics during any show cannot be understated. From vibrant full color fabric graphics, to direct printed panels, we provide the highest quality graphics & signage products available.

Listed below are some of the services we can provide:

- Vinyl Banners
- Fabric Banners
- Headers
- Large-format printing
- Posters
- Desktop Publishing

- Offset Printing
- Reprographic Printing
- Logo Reproduction
- POS displays
- Backdrops
- Stickers / Decals

- Specialty Graphics
- Vinyl Lettering
- Hanging Signs
- Backlit Graphics
- Silk Screening
- Laminating



Please contact your LVE Representative to create a graphic upload link.

Graphic Submission Guidelines

When submitting your artwork, these guidelines are vital to ensure your graphics look the very best.

1. All logos must be in a ***vector format**, saved in Adobe Illustrator or as an EPS file. Raster images will not be accepted - this includes .jpg, .png or .gif files copied directly from a web site.

* Art that can be scaled to any size without losing quality

2. All text should be converted to outlines or with the fonts provided. PC fonts only. All fonts must be embedded.
3. Photographic images should be 300 dpi at the final size in the layout in either JPG or TIF file format. **Sorry, Internet images cannot be used.**
 - Large continuous graphic walls 10ft wide or more need only be between 90 -150 dpi at actual size.
 - How an image is originally acquired will determine its resolution, and thus the size it can print at for clear and crisp printing.
 - Resolution and size (dimensions) are inversely proportional to each other. If you enlarge an image, you lower its resolution.
4. You must provide either a printed proof or a PDF proof when submitting artwork. This allows us to check the files for the font, color problems, missing links and more.

Acceptable Art Work



Good
quality
photo
clean
edges

- .pdf** - Adobe PDF (Fonts outlined - images embedded)
- .ai** - Adobe Illustrator (Fonts outlined - images embedded)
- .eps** - Encapsulated Post Script
- .tif** - (300 dpi at layout size)
- .psd** - Photoshop Document (All layers flattened)
- .zip** - Windows Compression Format

Unacceptable Art Work



Low
quality
photo
jagged
edges

- .indd** - InDesign
- .ppt** - PowerPoint
- .jpg** - Joint Photographic Experts Group
- .gif** - Graphic Interchange Format
- .png** - Portable Network Graphics
- .cdr** - CorelDraw



CHAMPS LAS VEGAS AUGUST 2026

AUGUST 26 - 28, 2026

LAS VEGAS CONVENTION CENTER - S1 & S2

| | |
|--------------|---------|
| COMPANY NAME | BOOTH # |
|--------------|---------|

DISPLAY LABOR

DEADLINE DATE:

8/5/2026

EXHIBIT INSTALLATION & DISMANTLING INFORMATION

| LABOR | BEGIN DATE | START TIME | SPECIAL EQUIPMENT | # OF LABORERS | EST. HOURS EA. | TOTAL HOURS |
|--------------|------------|------------|-------------------|---------------|----------------|-------------|
| INSTALLATION | | | | | | |
| DISMANTLING | | | | | | |

| LABOR | ESTIMATED CHARGES | HOURS | COST PER HOUR | TOTAL | |
|---|---|---------------|---------------|-------------|-------|
| | STRAIGHT TIME (ST) - One Hour Minimum | | \$ 170.00 | | |
| | OVERTIME (OT) - One Hour Minimum | | \$ 255.00 | | |
| | DOUBLE TIME (DT) - One Hour Minimum | | \$ 340.00 | | |
| LABOR ORDERED AFTER THE DEADLINE WILL BE THE RATE OF: ST \$240.00 OT \$360.00 DT \$480.00 | | | | | |
| <i>MINIMUM CHARGE FOR LABOR IS ONE HOUR. Time will be calculated to include gathering equipment, materials and travel to and from booth space. If your representative has not reported to the exhibitor services desk at the time the labor had been requested, or if ordered labor is not utilized, a one hour minimum will be charged for each man ordered.</i> | | | | | |
| STRAIGHT TIME - After 8:00 AM and prior to 4:30 PM Weekdays. OVERTIME - Prior to 8:00 AM and after 4:30 PM weekdays, and weekends. DOUBLE TIME - Holidays, or any job exceeding 12 work hours in one day. | | | | | |
| EQUIPMENT | HOURS | STRAIGHT TIME | OVERTIME | DOUBLE TIME | TOTAL |
| | FORKLIFT w/operator 0 to 4,000 lbs | \$ 398.00 | \$ 597.00 | \$ 796.00 | |
| | If specific equipment is needed, please contact Exhibitor Services for a quote. <i>If forklift w/operator is not utilized, there will be a fee of one hour per equipment w/operator ordered.</i> | | | | |

| SUPERVISION | <input type="checkbox"/> DO NOT PROCEED: The exhibitor will supervise the setup of their exhibit. Labor scheduled to begin other than 8:00 AM will be provided on a first come first serve basis. It is the exhibitors responsibility to request their labor at Exhibitor Services for all orders. |
|-------------|--|
| | <input type="checkbox"/> OK TO PROCEED (MUST FILL OUT FORM BELOW): LVE will supervise the setup of your exhibit. Your display will be installed and dismantled per your drawings and instructions. The exhibitor need not be present for this service. A 35% Supervision Fee will be added to the installation and dismantle invoice, (Minimum \$75.00). Your on-site personnel will be responsible for turning in Bills of Lading and shipping labels. |

LVE LABOR SUPERVISION FORM (NOTE: Your show site person is responsible for filling out Bills of Lading and Shipping Labels)

| | | | | | |
|--|---------------------------|---------------------------|--|---|------------------------------------|
| FREIGHT IS BEING SENT TO ADVANCED WAREHOUSE OR SHOW SITE | | | | <input type="checkbox"/> ADVANCED WAREHOUSE | <input type="checkbox"/> SHOW SITE |
| SPECIAL INSTRUCTIONS | | | | | |
| # OF CRATES | SET-UP PLANS IN CRATE # | SET-UP PLANS ATTACHED | | <input type="checkbox"/> YES | <input type="checkbox"/> NO |
| SHOW CARRIER <input type="checkbox"/> YES | # OF SKIDS TO SHRINK WRAP | PHOTO ATTACHED | | <input type="checkbox"/> YES | <input type="checkbox"/> NO |
| OWN CARRIER <input type="checkbox"/> YES | # OF SKIDS/CRATES TO BAND | SELF-CONTAINED UNIT | | <input type="checkbox"/> YES | <input type="checkbox"/> NO |
| If not using our official show carrier, please fill out the below. | | | | FACILITY FLOORING | |
| CARRIER NAME | PICK UP DATE | LVE RENTED CARPET | | <input type="checkbox"/> YES | <input type="checkbox"/> NO |
| CARRIER PHONE | PICK UP TIME | CARPET SENT WITH SHIPMENT | | <input type="checkbox"/> YES | <input type="checkbox"/> NO |

| CONSIGNEE (Where your freight is being shipped to when the show closes) | | | | BILLING INFORMATION (Responsible party paying your carrier's shipping charges) | | | |
|---|-------|---------|--|--|-------|---------|--|
| CO. NAME | | ADDRESS | | CO. NAME | | ADDRESS | |
| CITY | STATE | ZIP | | CITY | STATE | ZIP | |
| SHOW | | BOOTH # | | SHOW | | | |
| CONTACT | | | | CONTACT | | | |
| PHONE | | | | PHONE | | | |

Labor orders must be sent in by the deadline date to ensure labor availability.

Onsite orders will be handled on a first come first serve basis at the higher rate and upon availability.

Submit LVE forms to: exhibitorservices@lvexpo.com / FAX: 702-248-4113



10' x 10' BACKLIT KIT

KIT INCLUDES:

- 10' Wide x 8' High Back Wall with Fabric Graphics
- Center Fabric Graphic is Backlit
- 10 x 10 of Standard Carpet
- (5 choices of colors) - (Pad is Not Included)*
- (1) Counter with Front Sintra Graphic
- (2) Arm Lights *(Electrical Not Included)*
- (1) Black Stool
- (1) Wastebasket
- Transportation of rental exhibit to and from the show site
- Installation and Dismantle Labor of Exhibit
- Material Handling of LVE Exhibit Materials
- Onsite Customer Service

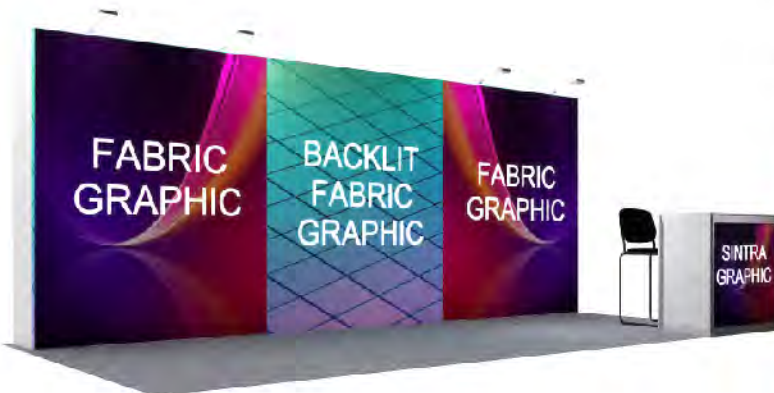

10' x 20' BACKLIT KIT

KIT INCLUDES:

- 20' Wide x 8' High Back Wall with Fabric Graphics
- Center Fabric Graphic is Backlit
- 10 x 20 of Standard Carpet
- (5 choices of colors) - (Pad is Not Included)*
- (1) Counter with Front Sintra Graphic
- (4) Arm Lights *(Electrical Not Included)*
- (1) Black Stool
- (1) Wastebasket
- Transportation of rental exhibit to and from the show site
- Installation and Dismantle Labor of Exhibit
- Material Handling of LVE Exhibit Materials
- Onsite Customer Service

Included furniture style may vary from photo

***** Please Note: When ordering LVE Rental Exhibit Kits**

- **Client to provide print-ready production artwork**
- **Additional accessories available upon request**
- **Electrical Power and Electrical Labor not included LVE Rental Exhibit Kits**



10' x 10' SEG KIT

KIT INCLUDES:

- 10' Wide x 8' High Back Wall with Fabric Graphics
- 10 x 10 of Standard Carpet
(5 choices of colors) - (Pad is Not Included)
- (1) Counter with Front Sintra Graphic
- (2) Arm Lights *(Electrical Not Included)*
- (1) Black Stool
- (1) Wastebasket
- Transportation of rental exhibit to and from the show site
- Installation and Dismantle Labor of Exhibit
- Material Handling of LVE Exhibit Materials
- Onsite Customer Service



10' x 20' SEG KIT

KIT INCLUDES:

- 20' Wide x 8' High Back Wall with Fabric Graphics
- 10 x 20 of Standard Carpet
(5 choices of colors) - (Pad is Not Included)
- (1) Counter with Front Sintra Graphic
- (4) Arm Lights *(Electrical Not Included)*
- (1) Black Stool
- (1) Wastebasket
- Transportation of rental exhibit to and from the show site
- Installation and Dismantle Labor of Exhibit
- Material Handling of LVE Exhibit Materials
- Onsite Customer Service

Included furniture style may vary from photo

***** Please Note: When ordering LVE Rental Exhibit Kits**

- **Client to provide print-ready production artwork**
- **Additional accessories available upon request**
- **Electrical Power and Electrical Labor not included LVE Rental Exhibit Kits**



10' x 10' SLATWALL KIT

KIT INCLUDES:

- 10' Wide x 8' High Back Wall
- 10 x 10 of Standard Carpet
(5 choices of colors) - (Pad is Not Included)
- (2) Arm Lights *(Electrical Not Included)*
- (1) Black Stool
- (1) Wastebasket
- (6) Shelves with Knife Brackets - Each Approx. 36" x 12"
- Transportation of rental exhibit to and from the show site
- Installation and Dismantle Labor of Exhibit
- Material Handling of LVE Exhibit Materials
- Onsite Customer Service



10' x 20' SLATWALL KIT

KIT INCLUDES:

- 20' Wide x 8' High Back Wall
- 10 x 20 of Standard Carpet
(5 choices of colors) - (Pad is Not Included)
- (4) Arm Lights *(Electrical Not Included)*
- (1) Black Stool
- (1) Wastebasket
- (12) Shelves with Knife Brackets - Each Approx. 36" x 12"
- Transportation of rental exhibit to and from the show site
- Installation and Dismantle Labor of Exhibit
- Material Handling of LVE Exhibit Materials
- Onsite Customer Service

**Sintra Graphics are NOT included with booth kits but can be ordered separately.*

***** Please Note: When ordering LVE Rental Exhibit Kits**

- **Client to provide print-ready production artwork**
- **Additional accessories and graphics may be ordered separately at an additional charge**
- **Electrical Power and Electrical Labor not included LVE Rental Exhibit Kits**



CHAMPS LAS VEGAS AUGUST 2026

AUGUST 26 - 28, 2026

LAS VEGAS CONVENTION CENTER - S1 & S2

| | | | |
|------------------------------|--|--------------------------------|--|
| COMPANY NAME | | BOOTH # | |
| MATRIX RENTAL SYSTEMS | | DEADLINE DATE: 8/5/2026 | |

| MATRIX RENTAL SYSTEMS | DESCRIPTION | QTY | DISCOUNT RECEIVED BY 8/5/2026 | STANDARD BEGINS 8/6/2026 | ONSITE BEGINS 8/20/2026 | TOTAL | |
|---|---|----------------------------------|----------------------------------|---|----------------------------|-------|--|
| | 10' X 10' SEG KIT | | \$ 3,893.05 | \$ 5,799.65 | N/A | | |
| | 10' X 20' SEG KIT | | \$ 6,159.08 | \$ 9,175.80 | N/A | | |
| | 10' X 10' BACKLIT KIT | | \$ 4,670.20 | \$ 6,957.99 | N/A | | |
| | 10' X 20' BACKLIT KIT | | \$ 8,937.18 | \$ 13,315.47 | N/A | | |
| | 10' SEG & BACKLIT KITS INCLUDE: | | | 20' SEG & BACKLIT KITS INCLUDE: | | | |
| | 10' W X 8' H Back Wall | | | 20' W X 8' H Back Wall | | | |
| | Counter with Front Graphic | | | Counter with Front Graphic | | | |
| | 10' x 10' Standard Carpet (5 choices of colors) | | | 10' x 20' Standard Carpet (5 choices of colors) | | | |
| | Circle one: <i>Black Blue Burgundy Gray Red</i> | | | Circle one: <i>Black Blue Burgundy Gray Red</i> | | | |
| | 2 Arm Lights | | | 4 Arm Lights | | | |
| | 1 Stool | | | 1 Stool | | | |
| | 1 Wastebasket | | | 1 Wastebasket | | | |
| | <p align="center"><i>Print ready artwork must be submitted 21 days prior to move-in.</i></p> <p align="center"><i>Additional fees will apply to late submissions. See Art Submission form for instructions.</i></p> | | | | | | |
| | SLATWALL KITS - Graphics not included | | | | | | |
| DESCRIPTION | QTY | DISCOUNT RECEIVED BY 8/5/2026 | STANDARD BEGINS 8/6/2026 | ONSITE BEGINS 8/20/2026 | TOTAL | | |
| 10' X 10' SLATWALL KIT** | | \$ 4,291.95 | \$ 6,008.75 | N/A | | | |
| 10' X 20' SLATWALL KIT** | | \$ 7,112.24 | \$ 9,957.13 | N/A | | | |
| **SLATWALL KIT DO NOT INCLUDE GRAPHICS OR ADDITIONAL ACCESSORIES | | | | | | | |

Additional accessories available on Matrix Accessories Form.

Exhibits Do Not include Electrical Power or Electrical Labor. Electrical forms must be sent to the Electrical Contractor.

CANCELLATION POLICY

Items cancelled after orders have been received will be charged 50% of the ordered price.

Items cancelled after show move-in begins will be charged 100% of the original price.

All materials are to remain the property of LVE.

Contact Exhibitor Services for Custom Booth Packages at 702.248.6200 or email us at exhibitorservices@lvexpo.com

CHAMPS LAS VEGAS AUGUST 2026

AUGUST 26 - 28, 2026

LAS VEGAS CONVENTION CENTER - S1 & S2

COMPANY NAME

BOOTH #

SLATWALL KIT ACCESSORIES
DEADLINE DATE:
8/5/2026
OPTIONAL ADDITIONAL ACCESSORIES

| SLATWALL ACCESSORIES | QTY | DISCOUNT RECEIVED BY 8/5/2026 | STANDARD BEGINS 8/6/2026 | ONSITE BEGINS 8/20/2026 | TOTAL |
|--------------------------------------|-----|----------------------------------|-----------------------------|----------------------------|-------|
| 1 Meter Counter | | \$ 420.00 | \$ 588.00 | \$ 672.00 | |
| 1M Shelf with Knife Brackets (WHITE) | | \$ 84.00 | \$ 109.20 | \$ 134.40 | |
| 1M Shelf with Knife Brackets (BLACK) | | \$ 84.00 | \$ 109.20 | \$ 134.40 | |
| 4" Slatwall Hook (BLACK)** | | \$ 15.75 | \$ 20.48 | \$ 22.84 | |
| 4" Slatwall Hook (CHROME)** | | \$ 15.75 | \$ 20.48 | \$ 22.84 | |
| 8" Slatwall Hook (BLACK)** | | \$ 17.75 | \$ 24.85 | \$ 28.40 | |
| 8" Slatwall Hook (CHROME)** | | \$ 17.75 | \$ 24.85 | \$ 28.40 | |
| 12" Slatwall Hook (BLACK)** | | \$ 19.00 | \$ 26.60 | \$ 30.40 | |
| 12" Slatwall Hook (CHROME)** | | \$ 19.00 | \$ 26.60 | \$ 30.40 | |
| Waterfall Bracket 6-Ball (BLACK)** | | \$ 68.25 | \$ 88.73 | \$ 98.96 | |
| Waterfall Bracket 6-Ball (CHROME)** | | \$ 68.25 | \$ 88.73 | \$ 98.96 | |
| Light | | \$ 120.75 | \$ 156.98 | \$ 184.80 | |

Electrical Power and Electrical Labor not included. Electrical forms must be sent to the Electrical Contractor

**** All Slatwall hooks and waterfall brackets will be delivered after you arrive.
Stop at the LVE Service Desk when you arrive to set up.**

SEE SAMPLE PICTURES ON FOLLOWING PAGE

CANCELLATION POLICY
Items cancelled after orders have been received will be charged 50% of the ordered price.
Items cancelled after show move-in begins will be charged 100% of the original price.
All materials are to remain the property of LVE.



SLATWALL HOOKS



6 BALL WATERFALL BRACKET



KNIFE BRACKET



SHELF WITH BRACKETS



FACEOUT BRACKET



LVE STEM LIGHT

CHAMPS LAS VEGAS AUGUST 2026

AUGUST 26 - 28, 2026

LAS VEGAS CONVENTION CENTER - S1 & S2

| | | | |
|---------------------|--|----------------|--|
| COMPANY NAME | | BOOTH # | |
|---------------------|--|----------------|--|

AGAM RENTAL EXHIBIT PACKAGES

DEADLINE DATE:

8/5/2026

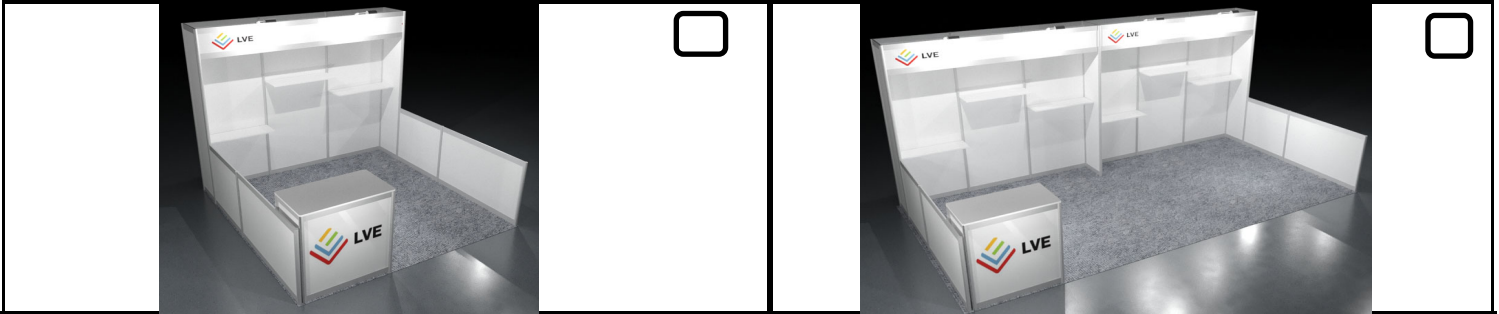

10' EXHIBIT RENTAL

20' EXHIBIT RENTAL

DISCOUNT PRICE \$ 3,564.75

DISCOUNT PRICE \$ 6,601.35

SEE BELOW FOR STANDARD AND ONSITE PRICES

| DISPLAY INCLUDES | DISPLAY INCLUDES |
|--|--|
| 10' Free Standing Display | 20' Free Standing Display |
| Silver Metal /Choice of Black or White Inserts | Silver Metal /Choice of Black or White Inserts |
| 3 Meter Header w/Company Name | 2 - 3 Meter Header w/Company Name |
| 2 Arm Lights | 4 Arm Lights |
| 3 Shelves | 6 Shelves |
| Carpet Gray | Carpet Gray |
| Installation and Dismantle | Installation and Dismantle |

Exhibits Do Not include Electrical Power or Electrical Labor. Electrical forms must be sent to the Electrical Contractor

Please select a PANEL COLOR OPTION

BLACK

WHITE

If color selection is not made at time of your order, your booth will automatically have white panels. The colors at show site are subject to availability.

| | |
|---------------------|--|
| HEADER | <p>Lettering will be standard black copy, background will be white. Be sure to clearly show spaces, upper and lowercase lettering. Logo is not included.</p> |
| HEADER COPY: | |

| OPTIONAL ACCESSORIES | | DISCOUNT RECEIVED BY 8/5/2026 | STANDARD BEGINS 8/6/2026 | ONSITE BEGINS 8/20/2026 | TOTAL |
|-----------------------------|--------------------------------|----------------------------------|-----------------------------|----------------------------|-------------|
| | | 10' Package | \$ 3,564.75 | \$ 4,990.65 | \$ 5,703.60 |
| | 20' Package | \$ 6,601.35 | \$ 9,241.89 | \$ 10,562.16 | |
| | 1 Meter Counter (Not Included) | \$ 420.00 | \$ 588.00 | \$ 672.00 | |
| | 2' x 8' Grid | \$ 257.25 | \$ 360.15 | \$ 411.60 | |
| | Shelves | \$ 84.00 | \$ 109.20 | \$ 134.40 | |
| | Slat Wall - White or Black | \$ 150.94 | \$ 208.95 | \$ 241.50 | |
| | Light | \$ 120.75 | \$ 156.98 | \$ 184.80 | |

Contact Exhibitor Services for Custom Booth Packages at 888.989.3976 or email us at exhibitorservices@lvexpo.com

CANCELLATION POLICY

*Items cancelled after orders have been received will be charged 50% of the ordered price.
 Items cancelled after show move-in begins will be charged 100% of the original price.
 Damage to rental items outside of normal wear and tear could result in exhibitor charges for replacement.
 All materials are to remain the property of LVE.*



CHAMPS LAS VEGAS AUGUST 2026

AUGUST 26 - 28, 2026
LAS VEGAS CONVENTION CENTER - S1 & S2

EAC AGREEMENT & FEES

DEADLINE DATE: **8/5/2026**

| | | | | | | | |
|---|----------|--|----------|-----|--|--|--|
| EAC COMPANY NAME | | | | | | | |
| EAC ONSITE CONTACT | | | | | | | |
| ADDRESS | | | | | | | |
| CITY | | STATE | | ZIP | | | |
| OFFICE PHONE | | ONSITE CONTACT'S CELLULAR PHONE | | | | | |
| EMAIL | | | | | | | |
| Registration / Admin Fee | \$350.00 | Late fee for each MHA turned in late, per hour. See show information page for deadline. | \$500.00 | | | | |
| Registration/Admin Fees are per Exhibiting company. All Fees are non-refundable once processed. | | | | | | | |

ADDITIONAL RULES FOR EAC

- EAC must supply a list of all booths they will be working in.
- EAC must submit a completed Work Authorization signed by both EAC and Exhibitor for each booth.
- EAC must have current COI on file with Las Vegas Expo.
- EAC must comply with all show and union rules.
- EAC must check in and obtain show credential to be on the show floor.
- EAC is responsible for turning in outbound MHA by deadline listed in the Show Information pages.
- LVE has the right to refuse any EAC access to the show floor should they not follow rules.
- LVE will communicate where credentials are to be picked up closer to the event.

I hereby acknowledge I have read the rules above and understand the penalties should our company not comply with said rules. Further, we have been provided with a copy of the Show Rules and Regulations as noted in the Exhibitor Manual and agree to abide by the same.

SIGN: _____

PRINT: _____

EAC CREDIT CARD CHARGE AUTHORIZATION (INFORMATION MUST BE PROVIDED)

| | | | | | | | | | | | | | | | |
|---|-------------------------------|-------------------------------------|---|--|------------------------|--|--|--|--|-----|--|--|--|--|--|
| <input type="checkbox"/> DISCOVER | <input type="checkbox"/> VISA | <input type="checkbox"/> MASTERCARD | <input type="checkbox"/> AMERICAN EXPRESS | | | | | | | | | | | | |
| ACCOUNT NUMBER | | | | | | | | | | | | | | | |
| EXPIRATION DATE | | | | | SECURITY CODE REQUIRED | | | | | | | | | | |
| <i>The security code can be found on the front of your Amex or on back of your Visa, Discover and MasterCard.</i> | | | | | | | | | | | | | | | |
| CARDHOLDER'S BILLING ADDRESS (IF DIFFERENT FROM ABOVE) | | | | | | | | | | | | | | | |
| CITY | | | | | STATE | | | | | ZIP | | | | | |
| CARDHOLDER'S NAME (PLEASE PRINT) | | | | | | | | | | | | | | | |
| CARDHOLDER'S SIGNATURE* X _____ | | | | | | | | | | | | | | | |

*By signing, I agree to the Terms and Conditions located within this manual. For your convenience, the above credit card information will be kept on file to be used for future shows and all outstanding balances.

Submit LVE forms to: exhibitorservices@lvexpo.com / FAX: 702-248-4113

CHAMPS LAS VEGAS AUGUST 2026

AUGUST 26 - 28, 2026
LAS VEGAS CONVENTION CENTER - S1 & S2

WORK AUTHORIZATION

DEADLINE DATE: 8/5/2026

All Exhibitors using an Exhibitor Appointed Contractor must return this form.
THIS FORM & CERTIFICATE OF INSURANCE MUST BE RETURNED BY THE STATED DEADLINE DATE.

We have selected the following Exhibitor-Appointed Contractor(s) (EACs). The EAC has been notified that a General Liability Insurance Certificate is required by Show Management and must be received by LVE no later than deadline date.

The contractor hired by the exhibitor must provide a certificate of insurance with at least the following limits:

Comprehensive General Liability not less than \$1,000,000 with respect to injuries to any person in one occurrence; \$2,000,000 with respect to injuries to more than one person in any one occurrence; and \$500,000 with respect to damage of property; Worker's Compensation Insurance, including employee liability coverage, in a minimum amount not less than \$1,000,000 of individual and/or aggregate coverage, and naming Show Management(Event Name) and Exhibitor as additional insured.

EAC COMPANY INFORMATION

| | | | |
|---|-------|-------------------------------|-----------------------------|
| EAC COMPANY NAME | | | |
| SERVICES TO BE PROVIDED | | | |
| EAC CONTACT PERSON(S) | | | |
| ADDRESS | | | |
| CITY | STATE | ZIP | |
| PHONE | FAX | | |
| EMAIL | | | |
| Is this company authorized to order services on your behalf? | | <input type="checkbox"/> YES | <input type="checkbox"/> NO |
| Is this company responsible for charges incurred for the show? <i>*If yes, both parties must complete and sign the Third Party form.</i> | | <input type="checkbox"/> YES* | <input type="checkbox"/> NO |
| EXHIBITING COMPANY | | | |
| PHONE | | | |
| BOOTH # (S) | | | |

I hereby authorize the company noted above to perform services on our behalf. Further, they have been provided with a copy of the Show Rules and Regulations as noted in the Exhibitor Manual and agree to abide by the same.

SIGN: _____ PRINT: _____

CERTIFICATE OF LIABILITY INSURANCE

PRODUCER: Insurance Agent/Broker who issues certificate.

NAME OF INSURED: Must be the legal name of contracting party

TYPES OF INSURANCE: Must include types required by contract. See Official Services Provider Information in this Exhibitor Manual.)

FORM OF COVERAGE: Must be "occurrence" form coverage

NAME ADDITIONAL INSURED: LVE (Official Service Provider), <show organizer name> (Show Management), <show name> (Show) and <facility name> (Facility) as additional insureds on a primary and non-contributory basis.

CERTIFICATE HOLDER: Must be LVE

POLICY EFFECTIVE DATE: Must be prior to or coincide with the first day of Exhibitor Move-In

POLICY EXPIRATION DATE: Must be on or after the last day of Exhibitor Move-Out

LIMITS OF INSURANCE: Must be the same or greater than required by contract. See Terms and Conditions located within this manual or online at www.lvexpo.com

AUTHORIZED REPRESENTATIVE: Must be signed (not stamped) by an authorized representative of Producer



SUBMIT YOUR CERTIFICATE OF LIABILITY INSURANCE ONLINE: <https://www.lvexpo.com/eacregistration/>

THIRD PARTY PAYMENT AUTHORIZATION

By submitting this form I authorize LVE to charge any additional amounts incurred by myself or my show representative, including material handling and/or labor charges. In the event the credit card provided declines, standard show site rate prevails and a \$25.00 service charge will be added. **CONVENIENCE FEE - All orders paid with a credit card will incur an additional non-refundable 3% fee.**

THIRD PARTY'S CREDIT CARD

| | | | | | | | | | | | |
|---|--|--|--------------------------------------|--------------|--|--|--|----------------|--|----------------|--|
| EXHIBITING COMPANY NAME | | | | | | | | | | | |
| EXHIBITING COMPANY | | | | | | | | BOOTH # | | | |
| THIRD PARTY'S CREDIT CARD CHARGE AUTHORIZATION (INFORMATION MUST BE PROVIDED) | | | | | | | | | | | |
| THIRD PARTY COMPANY | | | | | | PHONE | | | | | |
| THIRD PARTY CONTACT | | | | | | EMAIL | | | | | |
| ADDRESS | | | | | | | | | | | |
| CITY | | | | STATE | | | | ZIP | | BOOTH # | |
| <input type="checkbox"/> DISCOVER | | | <input type="checkbox"/> VISA | | | <input type="checkbox"/> MASTERCARD | | | <input type="checkbox"/> AMERICAN EXPRESS | | |
| ACCOUNT NUMBER | | | | | | | | | | | |
| EXPIRATION DATE | | | | | | | | | | | |
| <small>The security code can be found on the front of your Amex or on back of your Visa, Discover and MasterCard.</small> | | | | | | | | | | | |
| CARDHOLDER'S BILLING ADDRESS (IF DIFFERENT FROM ABOVE) | | | | | | | | | | | |
| CITY | | | | STATE | | | | ZIP | | | |
| CARDHOLDER'S NAME (PLEASE PRINT) | | | | | | | | | | | |
| CARDHOLDER'S SIGNATURE* | | | X _____ | | | | | | | | |
| <p>*By signing, I agree to the Terms and Conditions located within this manual. For your convenience, the above credit card information will be kept on file to be used for future shows and all outstanding balances.</p> <p style="text-align: center;"><i>Cancellation Policy varies per service as noted on each form.</i></p> | | | | | | | | | | | |
| SERVICES TO BE INVOICED TO THIRD PARTY | | | | | | | | | | | |

**Discount pricing applies only to orders received with full payment prior to the deadline date.
See each form for their specified deadline date.**

Damage to rental items outside of normal wear and tear could result in charges for replacement.

If you suspect you have potential errors on your charge card you have 60 days after the error appeared on your statement to contact us. You must notify us of the potential errors in writing.

CONVENIENCE FEE - All orders paid with a credit card will incur an additional non-refundable 3% fee.

Be advised, if a valid credit card is not provided prior to the shipment of your freight or ordering services, the card on file from the previous show will be charged. If you require us to change your form of payment and process a credit once the charge has processed there will be a \$75.00 processing fee. To avoid this charge, it is your responsibility to ensure that there is a valid card on file before submitting orders or shipping freight.

CHAMPS LAS VEGAS AUGUST 2026

AUGUST 26 - 28, 2026
LAS VEGAS CONVENTION CENTER - S1 & S2

| | |
|--------------|---------|
| COMPANY NAME | BOOTH # |
|--------------|---------|

MATERIAL HANDLING

(The PAYMENT AUTHORIZATION FORM must accompany this form)

ALL SHIPMENTS MUST BE PREPAID WITH CERTIFIED WEIGHT TICKETS. COLLECT SHIPMENTS WILL NOT BE ACCEPTED.

| | | | | | |
|--------------------------|---|------------------------------|------------------------------|------------------------------|------------------------------|
| MATERIAL HANDLING | 200 LBS MINIMUM | STANDARD | LATE | SPECIAL HANDLING | SPECIAL HANDLING LATE |
| | ADVANCE WAREHOUSE | \$ 190.00 Per 100 lbs | \$ 247.00 Per 100 lbs | \$ 256.50 Per 100 lbs | \$ 333.45 Per 100 lbs |
| | Crated/boxed exhibit material received at warehouse prior to show move-in, up to 30 days free storage and delivery to show site. LVE does not accept PAD WRAPPED SHIPMENTS at advanced warehouse all rates are per shipment received. See Show Information for delivery deadline dates. | | | | |
| | 200 LBS MINIMUM | STANDARD | LATE | SPECIAL HANDLING | SPECIAL HANDLING LATE |
| | SHOW-SITE | \$ 205.00 Per 100 lbs | \$ 266.50 Per 100 lbs | \$ 266.50 Per 100 lbs | \$ 346.45 Per 100 lbs |
| | Crated/boxed exhibit material received at show site. See Show Information for delivery deadline dates. | | | | |

**Material Handling rates are round trip rates,
there will be no additional handling fees at the show.**

| | | | | | |
|-----------------------|--|------------------------------------|---|------------------------------------|---|
| SMALL PACKAGES | PER SHIPMENT RECEIVED | WAREHOUSE FIRST PACKAGE | WAREHOUSE ADDITIONAL PACKAGE | SHOW SITE FIRST PACKAGE | SHOW SITE ADDITIONAL PACKAGE |
| | SMALL PACKAGE | \$ 85.00 | \$ 65.00 | \$ 99.75 | \$ 78.75 |
| | 30% Late fee if received after deadline date Maximum weight per shipment is 25lbs. Items received without documentation will be delivered without guarantee of piece count or condition. | | | | |

| | | | | | |
|---------------|----------------------------|------------------------------------|------------------------------------|-------------|------------------------|
| TOTALS | WEIGHT PER SHIPMENT | RECEIVING LOCATION | | RATE | ESTIMATED TOTAL |
| | | <input type="checkbox"/> WAREHOUSE | <input type="checkbox"/> SHOW SITE | | |
| | | <input type="checkbox"/> WAREHOUSE | <input type="checkbox"/> SHOW SITE | | |
| | | <input type="checkbox"/> WAREHOUSE | <input type="checkbox"/> SHOW SITE | | |
| | | <input type="checkbox"/> WAREHOUSE | <input type="checkbox"/> SHOW SITE | | |

USE THE SHOW SHIPPING LABELS DO NOT SHIP DIRECTLY TO THE FACILITY

| | | | | |
|---------------------|--|--|--|--|
| INSTRUCTIONS | All material handling rates include delivery to booth | | All shipping charges must be prepaid | |
| | Materials must arrive during published dates to avoid additional charges | | No collect shipments. "COD" | |
| | Shipments arriving at the warehouse after move-in will be late and will incur an additional delivery charge | | | |
| | SPECIAL HANDLING | | | |
| | UPS, FedEx, USPS, loose, uncrated exhibit material, van line | | Materials with no inbound documents | |
| | Material with no certified weights | | Materials with no pick points received | |
| | OVERTIME (OT) | | | |
| | PUBLISHED RATES LISTED ABOVE INCLUDE OVERTIME FEES. | | | |
| | Formula for estimating freight between 25 lbs. and 200 lbs.: Round up to minimum 200 lbs. <i>Example Only: Shipment to the warehouse weighing 89 lbs. Rounded to minimum of 200 lbs. at \$190.00 per 100 lbs = minimum charge of \$380.00</i> Formula to estimate charges over 200 lbs.: Number of lbs. Rounded to the next 100, divided by 100, x rate = estimated charges. <i>Example: Shipment to the warehouse weighing 328 lbs. Rounded to the next 100 = 400, divided by 100 = 4 x 190.00 = \$760.00</i> | | | |



LVE

WAREHOUSE DELIVERY

RECEIVING DATES WITHOUT LATE FEES

Monday, July 20, 2026 - Monday, August 10, 2026

TO:

EXHIBITOR NAME

C/O: LVE-IT VEGAS

**6225 Annie Oakley Drive
Las Vegas, NV 89120**

EVENT: CHAMPS LAS VEGAS AUGUST 2026

NO. _____ OF _____ PIECES

BOOTH #: _____



LVE

WAREHOUSE DELIVERY

RECEIVING DATES WITHOUT LATE FEES

Monday, July 20, 2026 - Monday, August 10, 2026

TO:

EXHIBITOR NAME

C/O: LVE-IT VEGAS

**6225 Annie Oakley Drive
Las Vegas, NV 89120**

EVENT: CHAMPS LAS VEGAS AUGUST 2026

NO. _____ OF _____ PIECES

BOOTH #: _____



LVE

DIRECT TO SHOW SITE

CAN ONLY BE DELIVERED

Monday, August 24, 2026 : 8:00 AM - 5:00 PM

Tuesday, August 25, 2026 : 8:00 AM - 7:00 PM

TO:

EXHIBITOR NAME

C/O: LVE

LAS VEGAS CONVENTION CENTER - S1 & S2

3150 Paradise Road

Las Vegas, NV 89109

EVENT: CHAMPS LAS VEGAS AUGUST 2026

NO. _____ OF _____ PIECES

BOOTH #: _____



LVE

DIRECT TO SHOW SITE

CAN ONLY BE DELIVERED

Monday, August 24, 2026 : 8:00 AM - 5:00 PM

Tuesday, August 25, 2026 : 8:00 AM - 7:00 PM

TO:

EXHIBITOR NAME

C/O: LVE

LAS VEGAS CONVENTION CENTER - S1 & S2

3150 Paradise Road

Las Vegas, NV 89109

EVENT: CHAMPS LAS VEGAS AUGUST 2026

NO. _____ OF _____ PIECES

BOOTH #: _____



CHAMPS LAS VEGAS AUGUST 2026

AUGUST 26 - 28, 2026

LAS VEGAS CONVENTION CENTER - S1 & S2

COMPANY NAME

BOOTH #

OUTBOUND SHIPPING INFORMATION

This form does not replace the Outbound Material Handling Agreement (MHA) that must be completed on site.

Exhibitors must pickup, complete and return the Outbound MHA to the LVE Exhibitor Service desk onsite. Shipments with no paperwork will incur additional charges and be return to the warehouse for disposition.

IF YOU DO NOT CHOOSE AN OPTION BELOW AND YOUR CARRIER DOES NOT SHOW UP ONSITE, YOUR FREIGHT WILL BE AUTOMATICALLY RE-ROUTED WITH THE SHOW CARRIER AT THE EXHIBITOR'S EXPENSE.

**Material Handling rates are round trip rates,
there will be no additional handling fees at the show.**

In the event your selected carrier does not show please select one of the following here below.

RE-ROUTE VIA SHOW CARRIER PER ABOVE INSTRUCTIONS OR RETURN SHIPMENT TO WAREHOUSE AT EXHIBITOR'S EXPENSE

NOTE: Exhibitor is responsible for contracting any carrier except those recommended in this manual. LVE will not be responsible for literature/products not properly packed and labeled by exhibit personnel.

I understand that LVE shall not be responsible for loss, theft or damage to any display installed or dismantled under LVE's supervision of labor, nor for any misdirected, delayed or lost shipment of said display. I further understand that it is my/our responsibility to provide LVE with complete and accurate written instructions for the packing and/or shipping of said display by LVE supervised labor. Payment of all services will be my/our responsibility as the exhibitor.

SIGN: _____ PRINT: _____ DATE: _____

Once your shipment is packed and ready to be picked up, please return the Material Handling Agreement to Exhibitor Services. SHIPMENTS WITHOUT PAPERWORK TURNED IN WILL BE RETURNED TO OUR WAREHOUSE AT THE EXHIBITOR'S EXPENSE. LVE will make arrangements for all LVE exhibit transportation shipments. Arrangements for pick-up by other carriers is the responsibility of the exhibitor.

RETURN FREIGHT & STORAGE

WAREHOUSE

Rates include delivery of shipment at close of show to LVE warehouse for storage or loading to outbound carriers. Freight that is crated or skidded and weighs 50 lbs. or more will be charged the following rates with a 1,000 lb. minimum.

| RETURN TO WAREHOUSE DRAYAGE & HANDLING | | | |
|--|----|--------|---------------------------------|
| SHIPMENTS OVER 50 POUNDS | \$ | 42.50 | per 100 lbs. (\$425.00 minimum) |
| SHIPMENTS LESS THAN 50 POUNDS | \$ | 150.00 | Flat Fee Per shipment |

The exhibitor is responsible to provide their own insurance. LVE provides only Limited Liability. See Limits of Liability forms. A LVE Outbound Material Handling Form is required to be completed on site at the close of the show for this service.

STORAGE

| | | | |
|----------------------|----|-------|--------------|
| MONTHLY STORAGE RATE | \$ | 11.00 | per 100 lbs. |
| WAREHOUSE HANDLING | \$ | 11.55 | per 100 lbs. |

Monthly storage rate is billed quarterly, at \$33.00 per 100 lbs. (1,000 lbs. minimum)

All freight must be crated, palletized or boxed to be eligible for storage. LVE reserves the right to refuse to store freight due to condition of the freight, past payment history, etc. A signed Storage Agreement is required for storage of your freight.

***By signing, I understand and agree that LVE reserves the right to remove and dispose of stored materials from our facility after 90 days of non-payment.**

SIGN*: _____ PRINT: _____ DATE: _____

ADVANTAGES OF STORING WITH LVE

- Save on expensive shipping charges.
- Storage freight is delivered to the show in advance of direct shipment.
- No Marshalling Yard, Check-in, or waiting
- Warehouse facilities and services are located in Las Vegas, Nashville, & Denver for year round access.
- 30 Days free storage included in LVE advance material handling rates.

The PAYMENT AUTHORIZATION FORM must accompany this form

DEADLINE DATE: August 5, 2026
STANDARD RENTAL INCLUDES:

- Hanging sign snap tube frame with a single or double-sided fabric graphic.
- *Labor and Hardware to hang the sign are NOT included* in the Standard Rental Price
- Custom Fabric Graphic, with carrying case (you own the graphic, yours to keep)

*** Orders received after the Discount Deadline date are subject to and will be charged late charges. ***



Single Sided: \$2,279.25 / Double Sided: \$2,484.45

Circle Signs
SNAP TUBE HANGING FRAME

Metal Fabrication

8' diameter x 36" h

Made with 1.5" round tube.

Eyebolts for hanging.

8' x 36" Ring Pillowcase Single Sided Graphic



Single Sided: \$4,259.55 / Double Sided: \$4,598.40

SNAP TUBE HANGING FRAME

Metal Fabrication

10' diameter x 48" h

Made with 1.5" round tube.

Eyebolts for hanging.

10' x 48" Ring Pillowcase Single Sided Graphic



Single Sided: \$4,768.50 / Double Sided: \$5,200.50

Square Signs
SNAP TUBE HANGING FRAME

Metal Fabrication

10' x 10' x 48" h

Square hanging frame

Made with 1.5" round tube.

Eyebolts for hanging

120" x 120" x 48" Square Pillowcase Single Sided Graphic

Custom Signs

 Additional Sizes and Solutions Available Upon Request: For further information, please email our Exhibitor Services Department at exhibitorservices@lvexpo.com, or call our office at 888.989.3976

COMPANY NAME
BOOTH #
HANGING SIGNS RULES AND REGULATIONS

Hanging signs, both electrical and non-electrical, are permitted at this event provided that doing so complies with show management rules and regulations. Exhibitors and display houses must adhere to all of the following conditions and limitations listed below:

- 1) Hanging Signs are not permitted in inline and linear booths.
- 2) All hanging signs must be sent to the LVE advance warehouse by the deadline, separate from your booth samples and/or merchandise. Use the hanging sign shipping label in this Exhibitor Service Manual. Note on your shipping documents "Hanging Signs." Failure to follow these shipping rules may result in your sign not being hung and you will be subject to the higher hanging sign rates.
- 3) Set-up instructions must be included with the Hanging Sign Order Form and in the Hanging Sign container. Orders without the placement diagram will result in the higher hanging sign rates.
- 4) All hanging signs must be assembled, installed and removed by LVE. Assembly by exhibitor or display house personnel is not permitted.
- 5) Final rigging of all hanging signs will be determined by LVE to ensure minimum stress to the supporting framework.
- 6) All structures and existing hardware will be inspected by the LVE rigging crew. All additional hardware will be charged accordingly. Structures that are deemed unsafe will not be hung. The exhibitor will be responsible for the labor spent attempting to assemble and hang such sign.
- 7) The specific placement of your hanging sign may differ from your original request based on the ceiling structure and support beams of the facility. This will be determined onsite by the LVE.
- 8) All electrical and neon signs must be in working order and conform to National Electric Code. Electricity for electrical signs is not included, this must be ordered by the exhibitor in advance with the electrical provider.
- 9) LVE will begin to assemble and hang the signs as soon as the hall is accessible as long as the order and the sign are received by the appropriate deadline dates.
- 10) Hanging Signs must not exceed the size of the booth.
- 11) LVE does not guarantee the hanging of signs when orders are not placed by the deadline.
- 12) You are required to make arrangements prior to move-out for the outbound dismantling, packing and shipping of your hanging sign. LVE cannot be held liable for damages or misplacement of signs(s) should outbound dismantling arrangements not be made. All pertinent information and arrangements must be given to the LVE Service Center.
- 13) Scheduling a specific time for your sign to be hung is not permitted.
- 14) Structural Integrity and placement form must be submitted with order.



CHAMPS LAS VEGAS AUGUST 2026

AUGUST 26 - 28, 2026

LAS VEGAS CONVENTION CENTER - S1 & S2

| | | | |
|--------------|--|---------|--|
| COMPANY NAME | | BOOTH # | |
|--------------|--|---------|--|

NON-ELECTRICAL HANGING SIGN - UNDER 200 LB

DISCOUNT DATE: 8/5/2026

- | | |
|--|--|
| • <i>Must be shipped separately</i> | • <i>Clearly marked with enclosed hanging sign label</i> |
| • <i>Received by discount receiving deadline</i> | • <i>Payment form must be included with this form</i> |
| • <i>Placement diagrams must accompany all orders.</i> | |

Above conditions must be met to receive advance pricing.

INSTRUCTIONS

- All ceiling rigging must conform to Show Management rules and regulations and facility limitations.
- All overhead hanging signs must be assembled and installed by LVE.
- Set up instructions must be provided for sign assembly.
- Hanging anchor points must be pre-fabricated.
- Show prices will apply to all labor orders placed at show site.
- RATES ARE PER HOUR, PER SIGN.
- Condor and Crew consists of condor, operator and rigger.
- Assembly and Ground Labor is an additional charge.
- Additional crew and/or equipment will be used if deemed necessary by LVE and will be charged accordingly.
- One hour minimum, thereafter is charged in half (1/2) hour increments.
- One hour minimum per lift/crew - lift/crew thereafter is charged in half (1/2) hour increments for each install and dismantle.
- LVE components (cable, clamps, etc) will be used to install all hanging signs and charged accordingly.

| RIGGING RATES | DISCOUNT RECEIVED BY | STANDARD BEGINS | ONSITE BEGINS | # OF SIGNS | RATE | TOTAL ESTIMATED COST |
|---|----------------------|-----------------|---------------|-------------------------------------|------|----------------------|
| | 8/5/2026 | 8/6/2026 | 8/20/2026 | | | |
| INSTALL RIGGING (per sign, per hour) | \$ 997.50 | \$1,470.00 | \$ 1,995.00 | | | |
| DISMANTLE RIGGING (per sign, per hour) | \$ 997.50 | \$1,470.00 | \$ 1,995.00 | 1/2 of install, minimum of 1 hour** | | |

**Dismantle rigging charges ("Labor Out") are billed at 1/2 of the installation time for rigging crew. Minimum of 1 hour.

| ASSEMBLY LABOR | DISCOUNT RECEIVED BY | STANDARD BEGINS | ONSITE BEGINS | APPROX. HOURS | HOURLY RATE | TOTAL ESTIMATED COST |
|---------------------------------------|----------------------|-----------------|---------------|---------------|-------------|----------------------|
| | 8/5/2026 | 8/6/2026 | 8/20/2026 | | | |
| 2 LABORS, MINIMUM ONE HOUR PER PERSON | \$ 210.00 | \$ 315.00 | \$ 420.00 | | | |

All overhead hanging signs must be assembled and installed by LVE.

ASSEMBLY LABOR will consist of a 2 person crew, minimim charge one hour per person.

LVE will begin to assemble and hang the signs as soon as the hall is accessible. This cannot be scheduled.

CANCELLATION POLICY

A 50% cancellation charge will be applied to orders cancelled after the deadline.

All onsite cancellations will be charged 100% of the original order.

Submit LVE forms to: exhibitorservices@lvexpo.com / FAX: 702-248-4113



CHAMPS LAS VEGAS AUGUST 2026

AUGUST 26 - 28, 2026
LAS VEGAS CONVENTION CENTER - S1 & S2

| | | | |
|--------------|--|---------|--|
| COMPANY NAME | | BOOTH # | |
|--------------|--|---------|--|

ELECTRICAL SIGNS / MOTORS / HANGING OF VIDEO WALLS

DISCOUNT DATE: 8/5/2026

- Must be shipped separately
- Received by discount receiving deadline
- Placement diagrams must accompany all orders.
- Clearly marked with enclosed hanging sign label
- Payment form must be included with this form

ABOVE CONDITIONS MUST BE MET TO RECEIVE ADVANCE PRICING.

| RIGGING RATES | DISCOUNT RECEIVED BY | STANDARD BEGINS | ONSITE BEGINS | # OF SIGNS | RATE | TOTAL ESTIMATED COST |
|--|----------------------|-----------------|---------------|-----------------------------------|------|----------------------|
| | 8/5/2026 | 8/6/2026 | 8/20/2026 | | | |
| INSTALL RIGGING (per sign, per hour) | \$ 1,286.25 | \$ 1,732.50 | \$ 2,677.50 | | | |
| DISMANTLE RIGGING (per sign, per hour) | \$ 1,286.25 | \$ 1,732.50 | \$ 2,677.50 | 1/2 of install, minimum of 1 hr** | | |

**Dismantle rigging charges ("Labor Out") are billed at 1/2 of the installation time for rigging crew. Minimum of 1 hour.

| ASSEMBLY LABOR | DISCOUNT | STANDARD | ONSITE | APPROX. HOURS | HOURLY RATE | TOTAL ESTIMATED COST |
|---------------------------------------|-----------|-----------|-----------|---------------|-------------|----------------------|
| 2 LABORS, MINIMUM ONE HOUR PER PERSON | \$ 210.00 | \$ 315.00 | \$ 420.00 | | | |

All overhead hanging signs must be assembled and installed by LVE

ASSEMBLY LABOR will consist of a 2 person crew, minimum charge one hour per person.

LVE will begin to assemble and hang the signs as soon as the hall is accessible. This cannot be scheduled.

RENTAL MOTORS & ROTATORS

| MOTOR DISCRPTION | DISCOUNT | STANDARD | ONSITE | QTY | TOTAL |
|-------------------------|-----------|-----------|-------------|-----|-------|
| HALF TON HOIST MOTOR | \$ 520.00 | \$ 730.00 | \$ 940.00 | | |
| ONE TON HOIST MOTOR | \$ 625.00 | \$ 898.00 | \$ 1,150.00 | | |
| HALF TON ROTATING MOTOR | \$ 520.00 | \$ 730.00 | \$ 940.00 | | |
| ONE TON ROTATING MOTOR | \$ 625.00 | \$ 898.00 | \$ 1,150.00 | | |

Motors ordered after the deadline are subject to availability.

We do not provide or rent video walls, you must make your own arrangements.

STRUCTURAL INTERGITY STATEMENT MUST ACCOMPANY ORDER

INSTRUCTIONS

- All ceiling rigging must conform to Show Management rules and regulations and facility limitations.
- All overhead hanging signs must be assembled and installed by LVE.
- Set up instructions must be provided for sign assembly.
- Show prices will apply to all labor orders placed at show site.
- Condor and Crew consists of condor, operator and rigger.
- Additional crew and/or equipment will be used if deemed necessary by LVE and will be charged accordingly.
- One hour minimum, thereafter is charged in half (1/2) hour increments.
- One hour minimum per lift/crew - lift/crew thereafter is charged in half (1/2) hour increments for each install and dismantle.
- LVE components (cable, clamps, etc) will be used to install all hanging signs and charged accordingly.
- Hanging anchor points must be pre-fabricated.
- RATES ARE PER HOUR, PER SIGN.
- Assembly and Ground Labor is an additional charge.

CANCELLATION POLICY

A 50% cancellation charge will be applied to orders cancelled after the deadline.
All onsite cancellations will be charged 100% of the original order.

Submit LVE forms to: exhibitorservices@lvexpo.com / FAX: 702-248-4113



CHAMPS LAS VEGAS AUGUST 2026

AUGUST 26 - 28, 2026
LAS VEGAS CONVENTION CENTER - S1 & S2

| | | | |
|--------------|--|---------|--|
| COMPANY NAME | | BOOTH # | |
|--------------|--|---------|--|

STRUCTURAL INTEGRITY STATEMENT

THIS FORM MUST BE RETURNED FOR ALL SUSPENDED STRUCTURES.

FAILURE TO SUBMIT THIS FORM COMPLETED MAY RESULT IN THE SIGN NOT BEING HUNG.

_____, the contracted exhibitor at the show and (if applicable), the display house or builder for the aforementioned exhibitor, do hereby certify and guarantee that the stress points for the hanging structure have been properly engineered and tested. We further certify that the structure can be hung safely and has been constructed to meet all applicable regulations and safety measures.

We hereby release, indemnify and forever hold harmless Show Management, the facility, LVE, and its' subsidiaries, their directors, officers, employees, representatives, agents and contractors from and against any and all liability, claims, damage, loss, fines, or penalties arising from the installation, use or dismantling of this structure. All hang points supporting in excess of 200 lbs. may be verified (metered) on site at exhibitor's expense.

| | | | | | |
|------------------|----------------------|---------|--|---------|--|
| EXHIBITOR | EXHIBITING COMPANY | | | BOOTH # | |
| | AUTHORIZED SIGNATURE | X _____ | | | |
| | AUTHORIZED NAME | | | DATE | |
| | EMAIL | | | | |

| | | | | | |
|----------------|---------------------------------------|---------|--|------|--|
| BUILDER | DISPLAY HOUSE/BUILDER (IF APPLICABLE) | | | | |
| | AUTHORIZED SIGNATURE | X _____ | | | |
| | AUTHORIZED NAME | | | DATE | |
| | EMAIL | | | | |

PLEASE INCLUDE THIS FORM WITH YOUR HANGING OR ELECTRICAL SIGN ORDER FORM

Submit LVE forms to: exhibitorservices@lvexpo.com / FAX: 702-248-4113



RUSH - HANGING SIGN

RECEIVING DATES WITHOUT LATE FEES
Monday, July 20, 2026 - Monday, August 10, 2026

TO: _____
EXHIBITOR NAME

c/o: LVE-IT VEGAS
6225 Annie Oakley Drive
Las Vegas, NV 89120

EVENT: CHAMPS LAS VEGAS AUGUST 2026

NO. _____ **OF** _____ **PIECES**

BOOTH #: _____



RUSH - HANGING SIGN

RECEIVING DATES WITHOUT LATE FEES
Monday, July 20, 2026 - Monday, August 10, 2026

TO: _____
EXHIBITOR NAME

c/o: LVE-IT VEGAS
6225 Annie Oakley Drive
Las Vegas, NV 89120

EVENT: CHAMPS LAS VEGAS AUGUST 2026

NO. _____ **OF** _____ **PIECES**

BOOTH #: _____

CHAMPS 2026

Las Vegas

August 26 - 28, 2026

AIRWAYS FREIGHT
LAND • AIR • SEA

Official Freight Carrier & Customs Broker
Worldwide Trade Show Transportation

- **Domestic & International**
- **Next or Second-Day Air**
- **Customs Broker on Staff**
- **LTL or Full Truckload**
- **Ocean LCL or Full Container**
- **24/7/365 Customer Service**



Priority freight handling by our partners at:



LVE

For immediate assistance 24/7/365
Call: 800.643.3525
Email: LVExpo@airwaysfreight.com

AIRWAYS FREIGHT
LAND • AIR • SEA

Serving the Trade Show Industry for 35+ years!



**LATE REQUESTS AND UNSCHEDULED
ONSITE ARRIVALS WILL NOT BE
PERMITTED ON THE SHOW FLOOR**

CHAMPS LAS VEGAS AUGUST 2026

AUGUST 26 - 28, 2026
LAS VEGAS CONVENTION CENTER - S1 & S2

| | |
|---------------------|----------------|
| COMPANY NAME | BOOTH # |
|---------------------|----------------|

VEHICLE SPOTTING SUBMISSION

Exhibitors may display a vehicle in their booth. Pursuant to Fire Department, please follow the steps below to ensure a smooth move-in process. The Fire Department requires a "Liquid or Gas-Fueled Vehicles or Equipment in Assembly Area" Permit for all booth vehicles.

PROCEDURE REQUIREMENTS

Exhibitors must complete the information below to obtain a permit from Fire Department through LVE. See information below.

Exhibitors must fill out the Vehicle Spotting Form and pay the spotting fee by **Deadline Date: Monday, July 20, 2026**

BLANKET PERMIT PROCEDURES

IF RECEIVED 6 WEEKS PRIOR TO SHOW DATE: To apply to be part of the Blanket Permit, the following must be included:

- | | |
|---|--|
| 1. Company name and booth number | 4. A picture of each vehicle to be displayed |
| 2. Contact name, email address, and cell phone | 5. All display structures or platforms for displaying the vehicles |
| 3. A site plan view of the location of each vehicle to be displayed | |

PERMIT THROUGH FIRE DEPARTMENT

IF APPLYING AFTER THE DEADLINE: Exhibitors who do not make the deadline, must contact us by phone for possible approval. Late requests are not guaranteed.

If exhibitors do not meet the deadline, they will not be permitted on the show floor.

Fire Department guidelines for vehicles can be accessed at: www.lvexpo.com

It is recommended you print the guidelines and submit along with your permit application.

MUST HAVE PRIOR APPROVAL AND PERMITS APPROVED - LATE SUBMISSIONS MAY BE DENIED. LATE RATES WILL BE QUOTED.

This applies to any vehicle to be displayed in the exhibit area. The following procedures and policies will apply:

LVE labor will direct the operator of the vehicle with passage into the exhibit area prior to the opening of the event and again at the conclusion of the event.

Any exhibitor freight or product brought inside your vehicle is subject to unloading and weighing. Show site material handling charges will apply.

LVE will verify that all Fire Department requirements are met and provide a drip cloth under the vehicle.

| The following costs will apply when submitted by the deadline date. Contact Exhibitor Service for late prices. | |
|--|---|
| \$ 393.75 | For each four wheel vehicle |
| \$ 30.00 | Added charge per each additional axle on vehicle to be applied to the standard cost |
| \$ 388.50 | Fire Marshal Permit Fee (non-refundable) |
| Exhibitors will be responsible for the following vehicle requirements: | |

The fuel tanks of vehicles must have LOCKABLE fuel filler cap to prevent escape of vapors and to avoid tampering.

Fire code stipulates that fuel in the fuel tanks shall not exceed 2 gallons or 1/8 of tank capacity, whichever is less.

Batteries must be disconnected. Auxiliary batteries not connected to engine starting system may be left connected. External transformers are recommended for demonstration purposes.

A fire extinguisher must be present, visible and accessible at all times.

Vehicles, boats or other motor craft equipment are not fueled or defueled within the building.

A 36-inch wide access aisle or clear space shall be maintained around all sides of the display vehicle. (72 inches between vehicles displayed together.) Vehicles shall be a minimum of 20-feet from exit doors, exit stairs, the exit access or exit passageways.

Vehicles shall not exhibit any leaks of any fluids and must have floor covering under the vehicle.

Proof of insurance for the vehicle and valid drivers license for the operator.

VEHICLE INFORMATION

| | | | | | |
|--------------|--|--------------|--|-------------|--|
| MAKE | | MODEL | | YEAR | |
| VIN # | | DIMS | | COST | |

NOTE: EXHIBITORS WILL BE RESPONSIBLE FOR THE OPERATION OF VEHICLE BOTH IN AND OUT OF THE FACILITY. ALL DRIVERS MUST PROVIDE LVE WITH PROOF OF INSURANCE AND VALID DRIVERS LICENSE.

The PAYMENT AUTHORIZATION FORM must accompany this form

Cancellation Policy

Services cancelled prior to the deadline date will be refunded 100% of the spotting fee. Fire Marshal Permit fees are non-refundable.

Spotting Services cancelled after the deadline date will be charged 50% of the price.

VEHICLE PREPARATION & SPOTTING FEE

Submit LVE forms to: exhibitorservices@lvexpo.com / FAX: 702-248-4113

LIMITS OF LIABILITY & RESPONSIBILITY**I. TERMS AND CONDITIONS**

These terms and conditions, limitations of liability, and time limitations are binding on all parties and their representatives, including Exhibitor Appointed Contractors, Installation & Dismantle personnel, as well as agents of the parties. They may be changed by LVE without notice. LVE assumes no liability in connection with Client's use and Client's supervision of union labor provided by LVE. Client agrees and understands that its employees and representatives attend the show site at their own risk.

All charges for services or materials are due in advance or at the time of order. A credit card on file and authorization to charge it is required to place an order. Payment may be made by credit card, check, or wire transfer. A credit card on file with LVE and authorization to charge it is required in order to pay by check or wire transfer. Fees for cancellation of an order can range up to the full amount of the order (up to 100%) depending on the pre-event work already performed, set up costs, and other factors. A non-refundable deposit will be required.

Outstanding balances must be paid by the end of the show. A late charge of 1.5% per month applies to any amounts not settled before the end of the event. LVE reserves the right to retain Client's goods in appropriate circumstances for amounts due which have not been settled. Client is responsible for all charges involved in the rendering of services or materials in the transaction with LVE, and for all amounts incurred in connection with the transaction with LVE which involve the event. Parties agree that the credit card provided to LVE may be charged for services, material handling, labor, and for other services and materials related to the transaction, including those provided by any third parties, representatives, or agents of the parties. By placing an order online or otherwise, client authorizes LVE to charge its credit card and agrees that LVE may charge the credit card provided to LVE by Client for any services, equipment, transportation, shipping, or materials as described and set forth in this Paragraph. Client authorizes LVE to charge all amounts to the credit card on file for said materials and services ordered by Client or Client's representatives as well as for said materials and services rendered to Client's company.

In order to obtain advance pricing, payment must be received and accepted by LVE prior to the deadline. After the conclusion of the event, LVE will make any adjustments to an invoice, if applicable. If Client is tax exempt in the state in which the event is held, a sales tax exemption certificate must be submitted to LVE.

Services and goods have separate, specific forms that apply to their order. Client must review the specific form that is applicable to the ordered service or materials for additional terms and conditions contained therein. LVE has a separate agreement with terms and conditions that apply to storage of goods. Client shall review LVE's form that pertains to the agreement for storage of goods for additional provisions that apply and authorize said form for the storage of any materials.

II. LIMITS OF LIABILITY & RESPONSIBILITY

1) The placing of an order for services, equipment, transportation, shipping, or materials by a client or any agent of the Client shall be construed as an offer subject to acceptance and approval of LVE in its sole discretion. Upon participation of any LVE show or event, the Client and its agents shall be bound by the terms and conditions set forth in Sections 2 through 8 below and Sections 1 through 7 in Part III. Likewise, once LVE has accepted and approved the Client's offer, any shipper consigning or delivering a shipment to LVE or its subcontractors on behalf of Client shall be bound by the terms and conditions set forth in Sections 2 through 8 below and Sections 1 through 7 in Part III.

2) LVE and its subcontractors shall not be liable for: damage to, or loss of, pieces of art; fragile equipment; electronics; uncrated freight; freight improperly packed or improperly labeled; glass breakage; concealed damage as determined by LVE; for delay to uncrated freight or freight improperly packed or labeled; or for ordinary wear and tear which occurs in the handling of the goods. Client shall package and label items properly before goods are moved or shipped; this includes making sure that goods are packed to withstand transport using forklifts, dollies, and related equipment.

3) Relative to inbound shipments, there may be a lapse of time between the delivery of shipment(s) to a booth by LVE or its subcontractors and the arrival of the Client's representative at the booth. Similarly, relative to outgoing shipment(s), it is possible that there will be a lapse of time between the completion of packing and the actual pick-up of materials from the booth for loading onto a carrier. It is understood that during such times the shipment(s) will be left in the booth unattended. Therefore, it is agreed that LVE and its subcontractors are not responsible for the loss or disappearance of, or damage to any items left in the booth unattended at any time, or for loss, disappearance, or damage occurring during the time the items are transported to dock and subsequently accepted by carrier. All bills of lading covering outgoing shipment(s) submitted to LVE or its subcontractors by Client will be checked at the time of pick-up from the booth and corrected where discrepancies exist. Received goods must be accompanied by documents showing appropriate details, such as bills of lading or suitable documents showing unit counts. If goods are not accompanied by such documents there shall be no guarantee as to the goods' condition or as to the piece count.

4) LVE and its subcontractors shall not be held liable for any damage incurred during the handling of equipment requiring special devices to properly load, place or reload, unless advance notice has been given to LVE in time to obtain the proper equipment.

5) LVE and its subcontractors shall not be held responsible for any loss, delay, or damage due to events beyond their reasonable control which cannot be avoided by the exercise of due care and prudence, including without limitation, strikes, labor disputes, lockouts or work stoppages of any kind, fire, theft, windstorm, water, vandalism, acts of God, failure of power or utilities, events of force majeure, actions or lack thereof of Client or other third parties, and the transportation of fragile items.

6) LVE and its subcontractors shall not be liable for ordinary wear and tear in the handling of materials and/or equipment. LVE shall not be responsible for damage to shrink wrapped items.

7) LVE and its subcontractors are not to be held liable for events of loss or damage to Client's property; that is, LVE does not insure the Client's property against loss or damage, nor does it provide full replacement value should loss or damage occur. Insurance, if any, shall be obtained by the Client. Amounts payable by LVE under this Paragraph are based on the scope of the liability as herein set forth and are unrelated to the value of the Client's property. Provisions of this paragraph shall apply if Client's property is lost or damaged through performance or nonperformance of services by LVE or from the negligence of LVE, its subcontractors, or their respective employees. If such loss or damage occurs, the liability of LVE and its subcontractors shall be limited to a sum equal to \$.30 per pound per article, with a maximum liability of \$50.00 per item or \$1,000.00 per shipment, whichever is less. This amount shall be considered Client's agreed-upon damages and exclusive remedy.

8) LVE will not be bound to honor any claim or action brought against LVE or its subcontractors more than 60 days after the date of incident.

LIMITS OF LIABILITY & RESPONSIBILITY CONTINUED**III. LIMITATION OF LIABILITY**

1) LVE AND ITS SUBCONTRACTORS SHALL NOT BE LIABLE TO ANY EXTENT WHATSOEVER FOR ANY INDIRECT, SPECIAL, INCIDENTAL, OR CONSEQUENTIAL DAMAGES, WHICH MAY INCLUDE, BUT ARE NOT LIMITED TO ANY ACTUAL, POTENTIAL OR ASSUMED LOSS OF PROFITS OR REVENUES, LOSS OF USE OF EQUIPMENT OR PRODUCTS, OR ANY COLLATERAL COSTS THAT MAY RESULT FROM ANY LOSS OR DAMAGE TO CLIENT'S MATERIALS OR ANY INJURY TO CLIENT'S PERSONNEL WHICH MAY MAKE IT IMPOSSIBLE OR IMPRACTICAL FOR CLIENT TO EXHIBIT ITS MATERIALS.

2) Client agrees in connection with the receipt, handling, temporary storage and reloading of its freight, that LVE and its subcontractors will provide these services as Client's agent and not as bailee or shipper. If any employees of LVE or its subcontractors sign a delivery receipt, bill of lading or other document, the parties agree that LVE or its subcontractors will do so as the Client's, and the Client shall accept the responsibility thereof.

3) LVE and its subcontractors shall not be liable for shipments received without receipts, freight bill, or specified unit counts on receipts or freight bills. Such shipments will be delivered to booth without guarantee of piece count or condition.

4) Empty container labels will be available at the LVE Service Desk. Affixing the labels is the sole responsibility of the Client or its representative. It is understood that these labels are used for Empty Storage only, and LVE and its subcontractors assume no responsibility or liability for loss or damage to contents while containers are in storage or for mislabeled containers.

5) In order to expedite removal of freight from the show site, LVE shall have the authority to change designated carriers, if assigned carriers do not pick up on time. Where the Client makes no disposition, freight will be taken to a warehouse or forced shipped on a carrier determined by LVE and the Client agrees to be responsible for payment charges relating to such handling and shipping. LVE assumes no liability as a result of such rerouting or handling.

6) Dry and Cold Storage – Client stores products at its own risk. LVE assumes no liability or responsibility for dry or cold storage.

7) The Client agrees, in the event of a dispute with LVE or its subcontractors related to any loss or damage to any of the Client's freight or equipment, that the Client will not withhold payment in any amount due to LVE for freight handling services or any other services provided by LVE or its subcontractors as an offset against the amount of the alleged loss or damage. Instead, the Client agrees to pay LVE prior to the close of the show for all such charges and further agrees that any claim the Client may have against LVE or its subcontractors shall be pursued independently by the Client as a completely separate transaction to be resolved on its own merits.

* * * * *

Be sure your freight is insured from the time it leaves your place of business until it is returned after the show. It is suggested that Clients arrange all risk coverage. Riders to existing policies can usually do this. Contact your insurance representative. Also, be sure your liability insurance is in effect during transmit and return of your freight, during storage, and at show site. All transit claims will be referred to the common carrier.

* * * * *

Client shall hold harmless, protect, defend, and indemnify LVE and LVE's subcontractors, its employees, agents, contractors, representatives, installation and dismantle persons, persons supervising union labor obtained through LVE, including reasonable attorney fees and court costs, for and against every claim, demand, damage, cause of action, suit or other litigation, without limit and without regard to the cause or causes thereof or the fault of any party, on account of or stemming from every instance of bodily injury to persons, or loss or damage to property other than goods, arising from performance of services.

The terms and conditions of this agreement and transaction with LVE shall be construed in accordance with and governed by the applicable laws of the United States of America and the laws of the State of Nevada where applicable. Any action or proceeding against LVE under or in connection with this Agreement or transaction with LVE, or any of the forms or Contract Documents involving LVE providing services or materials for the event, may be brought in the Courts of the State of Nevada, County of Clark.

* * * * *

I, the Client herein, agree that submitting my order online or otherwise shall constitute my acceptance of, and electronic signature to, this Agreement. I have read and understand all of the terms of this Agreement. By submitting this information to LVE, I hereby agree to, consent to, and authorize this Agreement and all of its terms.

SHOW SITE WORK RULES**** ATTENTION ******UNION JURISDICTION**

To simplify show preparation, we are certain you will appreciate knowing in advance that Union Labor will be required for certain aspects of your exhibit handling. To help you understand the show site work rules, we ask that you read the following.

EXHIBIT LABOR

Local Union has jurisdiction through a labor agreement with all contractors for the installation, touch-up painting, dismantling and repair of all exhibits. This work is to include wall coverings, floor coverings, pipe and drape, painting, hanging signs and decorative material from the ceiling, and the erection of platforms used for exhibit purposes. To secure labor, please utilize the labor form enclosed.

If full-time company personnel are utilized to set their exhibits, they must carry positive company identification such as medical identification card or payroll stub. This rule prohibits the utilization of workers hired from a non-union agency or company.

DEFINITION OF EXHIBITS THAT FULL-TIME COMPANY PERSONNEL MAY SET: 10 X 10, 10 X 20, KNOWN AS MOM & POP POP-UPS (NO GEM WALLS OR HARD WALL EXHIBITS MAY BE SET BY EXHIBITOR).

Local Union jurisdiction does not cover the placement of your products on display, the opening of cartons containing your products, nor the performance, testing, maintenance, or repairs of your machinery or products.

FREIGHT HANDLING

Local Union has jurisdiction through a labor agreement with the General Contractor for the loading and unloading of all trucks, trailers, and common and contact carriers as well as the handling of empty crates and the operation of material handling equipment and any mechanical devices such as forklifts, pallet jacks, hijackers, etc. The Local Union also has the jurisdiction of the unloading, uncrating, un-skidding, leveling, painted, and assembly of machinery and equipment and the reverse process.

The General Contractor has the responsibility of receiving and handling all the exhibit materials and empty crates. It is their responsibility to manage docks and schedule vehicles for the smooth and efficient move-in/move-out of the trade. Show.

An exhibitor may "hand carry" merchandise and "pop ups" only, provided they do not use material handling equipment to assist them, such as push carts, two or four wheel dollies or anything with wheels. When an Exhibitor chooses to "hand carry" materials they must utilize the "hand carry doors". They are not permitted to access to the loading dock/freight door areas. Please see the Hand Carry Policy contained in this kit for details.

Exhibitors may deliver materials to the loading dock/freight doors in their own personnel vehicle with the following restrictions:

1. The General Contractor has complete control of the loading dock at all times;
2. Exhibitors may not leave vehicles unattended at the loading areas. Any unattended vehicle may be towed.
3. All materials must be handled by the freight department and subject to the published material handling prices.

GRATUITIES

The General Contractor and I&D companies signatory to the contractor with Teamsters Local Union requires that exhibitors do not tip its employees by giving money, merchandise, or other special consideration for services rendered. Any attempts to solicit or take gratuity by an employee for any service, should be reported immediately to a supervisor of the contractor. Contracted employees are paid an excellent wage, and tipping is not an accepted policy.

All craftsmen dealing with exhibitors will do so in a courteous and professional manner. All questions arising with regard to the Union's jurisdiction or practices must be directed to the General Contractor and the Union.

FIRE & SAFETY REGULATIONS**NOTICE: SMOKING IS PROHIBITED IN EXHIBIT AREAS DURING MOVE-IN AND MOVE-OUT DUE TO THE ACCUMULATION OF COMBUSTIBLE MATERIALS.**

1. ALL MATERIALS USED IN CONSTRUCTION AND DECORATION OF AN EXHIBIT MUST BE CERTIFIED AS FLAME RETARDANT. Fabrics must be certified as flame retardant or a sample must be available for testing. Materials that cannot be treated to meet requirements, may not be used. A flame-proofing certificate should be available for inspection.
2. ALL EXITS AND AISLES MUST BE KEPT CLEAR AND UNOBSTRUCTED. No furniture, signs, easels, chairs, or displays may protrude into aisles.
3. DESIGNATED "NO FREIGHT" AISLES MUST BE MAINTAINED CLEAR OF CRATES AND EXHIBIT MATERIALS DURING MOVE-IN AND MOVE-OUT. These aisles are required for emergency access throughout the hall and to expedite freight and empty crate moving.
4. ALL FIRE HOSE RACKS, FIRE EXTINGUISHERS AND EMERGENCY EXITS MUST BE VISIBLE AND ACCESSIBLE AT ALL TIMES. This includes fire protection equipment located within exhibits. Exits and exit signs must not be covered by drapes or obscured from view by exhibit components.
5. VEHICLES ON DISPLAY MUST HAVE FUEL FILLER CAPS LOCKED OR SEALED TO PREVENT ESCAPE OF VAPORS AND TO AVOID TAMPERING. Fire code stipulates that fuel in fuel tanks shall not exceed 5 gallons or 1/4 of tank capacity, whichever is less. Batteries must be disconnected. Auxiliary batteries not connected to engine starting system may be left connected. External transformers are recommended for demonstration purposes. A fire extinguisher must be present, visible, and accessible at all times.
6. COMBUSTIBLE MATERIALS MUST NOT BE STORED BENEATH DISPLAY VEHICLES. Space beneath vehicles must be clear and visible except for permitted electrical supplies.
7. VEHICLES IN THE BUILDING FOR UNLOADING MUST NOT BE LEFT WITH ENGINES IDLING. Exhaust gases present extreme hazards to workers on catwalks. If the engine cannot be shut down, the vehicle must be removed from the building as quickly as possible.
8. ALL 110-VOLT EXTENSION CORDS SHALL BE GROUNDED THREE WIRE, #14 OR LARGER AWG COPPER WIRE. Connectors must not be supported by cords. Two wire, "Zip Cords" are not permitted other than factory installed appliance connectors; these may not exceed (6) feet in length and must be UL approved with built in over-load protectors.
9. COMPRESSED GAS CYLINDERS, INCLUDING LPG, ARE PROHIBITED UNLESS APPROVED BY FIRE SAFETY OFFICE. Flammable gases, i.e.: butane, propane, natural gas; are subject to prior approval. Compressed gas cylinders cannot be stored inside the building. After show hours, gas cylinders must be removed from the show floor and stored outside or off-site.
10. CUBE TAP ADAPTERS ARE PROHIBITED (UNIFORM FIRE CODE 85.107). MULTI-PLUG ADAPTERS MUST BE UL APPROVED AND HAVE BUILT-IN OVERLOAD PROTECTION. Connectors must not be used to exceed their listed ampere rating.
11. ELECTRICAL WORK UNDER CARPETS MUST BE DONE, OR SUPERVISED, BY THE OFFICIAL CONTRACTOR'S ELECTRICIANS. All wiring on the floor must be Type "SO" cord, insulated to qualify for "extra hard usage", must be No. 12AWG or larger, and must be protected against injury. All temporary wiring must be accessible and free from debris and storage materials. Hard backed booths must be at least 9 inches from rear booth lines and 18 inches between hard walls.
12. NO STORAGE OF ANY KIND IS ALLOWED BEHIND BOOTHS OR NEAR ELECTRICAL SERVICE. Materials necessary to the exhibit must be stored within the exhibit. Electrical cords and connectors must be accessible and shall not be covered. Areas enclosed by solid walls and ceilings must be provided with approved smoke detectors.
13. ALL EMPTY CARTONS OR CRATES MUST BE LABELED AND REMOVED FOR STORAGE OR THEY WILL BE REMOVED AS TRASH. Crates or raw flammable materials are not to be used as exhibit supports.
14. MATERIALS FOR HANDOUTS MUST BE LIMITED TO A ONE-DAY SUPPLY AND MUST BE STORED NEATLY WITHIN THE BOOTH. Violators will be notified and if not removed by show opening, show decorator will remove and store at EXHIBITOR'S EXPENSE. All storage must be kept clear of electrical cables or junction boxes.
15. FLAMMABLE OR COMBUSTIBLE LIQUIDS ARE PROHIBITED INSIDE OF BUILDINGS EXCEPT AS APPROVED BY THE FIRE SAFETY OFFICE. Flammable thinners, solvents and paints, including aerosol cans are strictly prohibited within the building.

FREQUENTLY ASKED FREIGHT QUESTIONS**WHEN CAN I SHIP TO THE WAREHOUSE?**

We will begin accepting freight 30 days prior to move-in.

The warehouse will receive shipments Monday through Friday 8:00 AM - 3:30 PM.

To ensure timely arrival of your materials at show site, freight should arrive by the deadline date listed on the Show Information page. Your freight will be accepted after the deadline date, however additional charges will be incurred.

HOW DO I LABEL MY FREIGHT?

The label should include the exhibiting company, the booth number, the name of the event and addresses c/o LVE.

The specific shipping address for the warehouse is located on the Show Information page.

It is best to label every carton on a skid with at least your company name and booth number. For your convenience we have provided labels in the exhibitor manual.

WHAT HAPPENS TO MY EMPTY CONTAINERS DURING THE SHOW?

Pick up "Empty Labels" at Exhibitor Services. Place a label on each container. Labeled containers will be picked up periodically and stored during the show.

At the close of the show, the empty containers will be returned to the booth in random order. Depending on the size of the show, this process may take several hours.

HOW DO I SHIP MY MATERIALS AFTER THE CLOSE OF THE SHOW?

Each shipment must have a completed LVE Outbound Material Handling Form in order to ship materials from the show. All pieces must be labeled individually. (You can pick these items up at LVE Exhibitor Services.)

After materials are packed, labeled, and ready to be shipped, the completed LVE Outbound Material Handling Form must be turned in to LVE Exhibitor Services.

Make arrangements with your designated carrier to pick up your shipment at the address of the facility where the event is taking place. Please refer to the Show Information pages for the specific dates and times. In the event your selected carrier fails to show, the shipment will be rerouted to the preferred carrier at the exhibitor's expense.

For your convenience, the preferred show carrier will be on site to handle outbound transportation.

You must notify your carrier of the date and times of pick up.

PLEASE COMPLETE ORDER FORM
AND EMAIL TO:
Robin@anglesondesign.com

CUSTOM FURNITURE RENTAL

Provided by Angles On Design
6175 S. Sandhill Road, Suite 300, Las Vegas, NV 89120
Phone: 702.798.6433 Fax: 702.309.1066
Billing/Corporate Office:
9655 Soreng Avenue, Suite 300, Schiller Park, IL 60176
www.anglesondesign.com

Show:
Show Dates:

Location:
Deadline:

| ITEM # | DESCRIPTION | COLOR | DISC | REG | QTY | TOTAL |
|-------------------------|--------------------------|--------------|------|-----|-----|-------|
| | | | \$ | \$ | | |
| CHAIRS | | | | | | |
| CH100 | JACOBSON CHAIR | WH | 120 | 150 | | |
| CH102 | MONACO CHAIR | BK | 130 | 165 | | |
| CH103 | CAZMA CHAIR | BK RD | 150 | 195 | | |
| CH104 | TOLEDO CHAIR | NAT | 135 | 170 | | |
| CH106 | CRISS CROSS CHAIR | WH | 135 | 170 | | |
| CH107 | PARIS CHAIR | WH/CH WH/NAT | 150 | 195 | | |
| CH109 | LIQUID CHAIR | BU OR RD WH | 150 | 195 | | |
| CH111 | TICINO CHAIR | WH | 150 | 195 | | |
| CH112 | RETRO CHAIR | ST | 130 | 165 | | |
| CH113 | LESLIE CHAIR | WH | 130 | 165 | | |
| CH114 | TENDY CHAIR | BK WH WL | 130 | 165 | | |
| CH116 | BELLA CHAIR | BK WH | 150 | 195 | | |
| CH118 | EURO CHAIR | BK WH | 135 | 170 | | |
| CH120 | SKYE CHAIR | CL | 150 | 195 | | |
| CH121 | MIA CHAIR | WH | 150 | 195 | | |
| CH124 | WAVE CHAIR | CL | 150 | 195 | | |
| CH125 | CASPER CHAIR | BK WH | 135 | 170 | | |
| BAR STOOLS | | | | | | |
| ST202 | MONACO STOOL | BK | 165 | 210 | | |
| ST203 | EQUINO STOOL, Adj. | BK WH | 195 | 245 | | |
| ST204 | TOLEDO STOOL | NAT | 180 | 230 | | |
| ST206 | CRISS CROSS STOOL | WH | 165 | 210 | | |
| ST207 | PARIS STOOL | WH/CH WH/NAT | 185 | 235 | | |
| ST209 | LIQUID STOOL | BU OR RD WH | 190 | 240 | | |
| ST210 | OTTO STOOL, Adj. | BK WH | 180 | 225 | | |
| ST211 | TICINO STOOL | WH | 190 | 240 | | |
| ST212 | RETRO STOOL | ST | 170 | 215 | | |
| ST214 | TENDY STOOL | BK WH WL | 165 | 210 | | |
| ST216 | BELLA STOOL | BK WH | 190 | 240 | | |
| ST218-AEURO STOOL, Adj. | BK WH | 185 | 235 | | | |
| ST218-2 EURO 2 STOOL | BK WH | 185 | 235 | | | |
| ST219 | TECH STOOL, Adj. | WH | 180 | 225 | | |
| ST220 | SKYE STOOL | CL | 190 | 240 | | |
| ST221 | MIA STOOL | WH | 190 | 240 | | |
| ST222 | BRAXTON STOOL | BK WH | 190 | 240 | | |
| ST223 | CHLOE STOOL | CL | 190 | 240 | | |
| ST224 | WAVE STOOL | CL | 190 | 240 | | |
| CAFÉ TABLES | | | | | | |
| CT300 | PEDESTAL TABLE 24" | BK WH | 175 | 220 | | |
| CT301 | PEDESTAL TABLE 30" | BK WH | 185 | 235 | | |
| CT302 | CAFE TABLE 36" | BK WH GY | 195 | 245 | | |
| CT303 | CAFE TABLE 42" | BK WH GY | 205 | 260 | | |
| CT304 | SQUARE CAFE TABLE 30" | BK WH | 190 | 240 | | |
| CT305 | SQUARE CAFE TABLE 36" | BK WH | 200 | 255 | | |
| CT306 | TRAVE TABLE 36"DIA | GLASS | 205 | 260 | | |
| CT307 | BISTRO TABLE 30"DIA | NAT BK WH | 185 | 235 | | |
| CT309 | PARIS CAFE TABLE | WH/NAT | 205 | 260 | | |
| CT310 | CHROMA TABLE 27.5 Square | ALUMINUM | 175 | 220 | | |
| CT311 | CHROMA TABLE 27.5 Round | ALUMINUM | 175 | 220 | | |
| CT312 | RETRO TABLE | ST | 190 | 240 | | |
| CT313 | MARTINI TABLE 36" | GL | 205 | 260 | | |
| CT314 | ABBY CAFE TABLE | WH | 225 | 290 | | |
| CT353 | ALTOS TABLE 36X60 | GLASS | 285 | 370 | | |
| CT355 | ABBY TABLE 36X60 | WH | 285 | 370 | | |

| ITEM # | DESCRIPTION | COLOR | DISC | REG | QTY | TOTAL |
|---|---------------------------|----------------|------|-----|-----|-------|
| | | | \$ | \$ | | |
| CT357 | EDGE CAFE TABLE | WH | 500 | 650 | | |
| CT357-PEDGE CAFE TABLE w/power | WH | 600 | 780 | | | |
| BAR TABLES AND BARS | | | | | | |
| BT400 | PEDESTAL BAR TABLE 24" | BK WH | 185 | 235 | | |
| BT401 | PEDESTAL BAR TABLE 30" | BK WH | 195 | 245 | | |
| BT402 | BAR HIGH TABLE 36" | BK WH GY | 215 | 275 | | |
| BT404 | SQUARE BAR TABLE 30" | BK WH | 200 | 255 | | |
| BT405 | SQUARE BAR TABLE 36" | BK WH | 210 | 270 | | |
| BT406 | TRAVE BAR TABLE 32"DIA | GLASS | 225 | 290 | | |
| BT407 | BRAVO BAR TABLE 30"DIA | NT BK WH | 195 | 250 | | |
| BT410 | CHROMA TABLE 23.5" DIA | ALUMNUM | 185 | 235 | | |
| BT412 | RETRO BAR TABLE 24"SQ. | ST | 200 | 255 | | |
| BT413 | MARTINI BAR TABLE 32" DIA | GL | 220 | 285 | | |
| BT450 | MANHATTAN BAR | STAINLESS | 645 | 835 | | |
| BT451 | INFORMATION COUNTER | BK WH | 475 | 610 | | |
| BT454 | BALI BAR | BK WH | 475 | 610 | | |
| BT454-PBALI BAR w/power | BK WH | 560 | 720 | | | |
| BT457 | EDGE COMMUNAL BAR TABLE | BK WH | 560 | 720 | | |
| BT457-PEDGE COMMUNAL w/power | BK WH | 660 | 855 | | | |
| MODULAR PEDESTALS (BT486 for use with BT480-BT484) | | | | | | |
| BT480 | MOD CYLINDER PEDESTAL 18 | WH | 160 | 205 | | |
| BT481 | MOD CYLINDER PEDESTAL 30 | WH | 185 | 235 | | |
| BT482 | MOD CYLINDER PEDESTAL 42 | WH | 215 | 275 | | |
| BT483 | MOD CUBE 24X24 | WH | 185 | 235 | | |
| BT484 | MOD CUBE PEDESTAL 21X42 | WH | 215 | 275 | | |
| BT486 | LED LIGHT BOX w/remote | MULTI (RBGW) | 100 | 125 | | |
| CONFERENCE AND OFFICE CHAIRS | | | | | | |
| CO501 | OTTO GUEST CHAIR | BK WH | 185 | 235 | | |
| CO502 | OTTO CHAIR | BK WH | 195 | 250 | | |
| CO507 | GUEST CHAIR | BK | 150 | 195 | | |
| CO508 | MIDBACK CHAIR | BK | 175 | 225 | | |
| CO509 | STACKABLE SIDE CHAIR | BK | 90 | 115 | | |
| CO510 | STACKABLE ARM CHAIR | BK | 95 | 120 | | |
| CO512 | TASK CHAIR | BK | 125 | 160 | | |
| CO513 | TASK STOOL | BK | 150 | 190 | | |
| CO518 | RECEPTION CHAIR | BK | 185 | 235 | | |
| CO520 | ZURICH HIGHBACK CHAIR | BK WH | 290 | 375 | | |
| CONFERENCE TABLES | | | | | | |
| CF603 | CONFERENCE TABLE 48"DIA | BK WH GY CG MP | 350 | 455 | | |
| CF604 | GLACIER CONFERENCE TABLE | WH | 530 | 685 | | |
| CF605 | RECTANGULAR TABLE 6' | BK CG MP WH | 440 | 570 | | |
| CF606 | OVAL CONFERENCE TABLE 6' | BK WH GY | 440 | 570 | | |
| CF608 | OVAL CONFERENCE TABLE 8' | BK WH GY | 500 | 645 | | |
| CF609 | RECTANGULAR TABLE 8' | BK WH | 500 | 645 | | |
| CF610 | OVAL TABLE 10' | BK WH | 615 | 795 | | |
| CF611 | RECTANGULAR TABLE 10' | BK WH | 615 | 795 | | |
| OFFICE FURNITURE | | | | | | |
| OF653 | STORAGE CABINET, LOCKING | BK WH | 325 | 420 | | |
| OF659 | STORAGE CREDENZA | WH | 415 | 535 | | |
| OF660 | GLACIER SIDEBBOARD | WH | 505 | 650 | | |
| OF670 | PARSON DESK | GY WH | 300 | 385 | | |
| LOUNGE SEATING | | | | | | |
| LG706 | SCANDIC LEATHER SOFA | BK RD WH | 480 | 620 | | |
| LG707 | SCANDIC LEATHER LOVESEAT | BK RD WH | 445 | 580 | | |

Company Name: _____

Phone#: _____

Booth #: _____

| ITEM # | DESCRIPTION | COLOR | DISC | REG | QTY | TOTAL |
|---------------------------|--------------------------|-------------------|------|-----|-----|-------|
| LOUNGE SEATING | | | | | | |
| | | | \$ | \$ | | |
| LG708 | SCANDIC LEATHER CHAIR | BK RD WH | 410 | 530 | | |
| LG709 | PRATO ARM CHAIR | BK WH | 360 | 450 | | |
| LG710 | PRATO ARMLESS SECTIONAL | BK WH | 250 | 360 | | |
| LG711 | PRATO CORNER SECTIONAL | BK WH | 335 | 435 | | |
| LG712 | SOLO SOFA | BK RD | 445 | 580 | | |
| LG713 | SOLO LOVESEAT | BK RD | 410 | 530 | | |
| LG714 | SOLO CHAIR | BK RD | 385 | 485 | | |
| LG715 | MALIBU SOFA W/POWER | BK WH | 540 | 655 | | |
| LG716 | MALIBU CHAIR W/POWER | BK WH | 445 | 580 | | |
| LG717 | IBIZA CHAIR | BK WH | 445 | 580 | | |
| LG718 | BRENTWOOD SOFA | GY | 445 | 580 | | |
| LG724 | MALIBU LOVESEAT W/POWER | WH | 510 | 660 | | |
| LG731 | SOHO CURVED BENCH | WH | 360 | 450 | | |
| LG732 | SOHO LOVESEAT | WH | 390 | 500 | | |
| LG733 | TRIBECA LEATHER SOFA | GY | 550 | 700 | | |
| LG734 | TRIBECA LEATHER LOVESEAT | GY | 525 | 665 | | |
| LG735 | TRIBECA LEATHER CHAIR | GY | 480 | 620 | | |
| LG736 | ASPEN SOFA | WH | 480 | 620 | | |
| LG737 | ASPEN CHAIR | WH | 420 | 545 | | |
| LG747 | ANTON CHAIR | PEARL | 410 | 530 | | |
| LG749 | TICINO SETTEE | WH | 330 | 420 | | |
| LG750 | BENCH OTTOMAN | BK WH | 230 | 290 | | |
| LG753 | ROUND SWIVEL OTTOMAN | BK WH OR | 180 | 230 | | |
| LG755 | BLOCK OTTOMAN | BU BK RD WH | 140 | 170 | | |
| LG757 | RECTANGLE OTTOMAN | BK WH | 195 | 245 | | |
| LG758 | AURORA SOFA | WH | 550 | 700 | | |
| LG759 | AURORA CHAIR | WH | 510 | 660 | | |
| LG762 | AURORA LOVESEAT | WH | 525 | 675 | | |
| LG763 | JAVA BENCH 6' | NAT | 235 | 295 | | |
| LG780 | STEN SWIVEL CHAIR | BK RED WH | 290 | 365 | | |
| LG784 | AVA CHAIR | WH | 290 | 365 | | |
| LG785 | LARGO CHAIR | WH | 290 | 365 | | |
| LG786 | SWAN CHAIR | BK WH | 290 | 365 | | |
| OCCASSIONAL TABLES | | | | | | |
| OT804 | TUSCAN COCKTAIL TABLE | TK | 250 | 310 | | |
| OT805 | TUSCAN END TABLE | TK | 220 | 270 | | |
| OT808 | VAIL COCKTAIL TABLE | GL | 225 | 290 | | |
| OT809 | VAIL END TABLE | GL | 195 | 245 | | |
| OT810 | BELLO COCKTAIL TABLE | WH | 235 | 295 | | |
| OT811 | BELLO END TABLE | WH | 205 | 255 | | |
| OT817 | KEMI COCKTAIL TABLE | CH/GL | 225 | 290 | | |
| OT818 | KEMI END TABLE | CH/GL | 195 | 245 | | |
| OT821 | VEGA TABLE 18" DIA Adj. | BK BU GR RD WH YL | 135 | 165 | | |
| OT823 | VORTEX TABLE | BK WH | 185 | 235 | | |
| OT824 | VENTURA COFFEE TABLE | ST/WL | 225 | 285 | | |
| OT825 | VENTURA END TABLE | ST/WL | 185 | 235 | | |
| OT826 | CRYSTAL COCKTAIL TABLE | GL | 225 | 2 | | |
| OT827 | CRYSTAL END TABLE | GL | 185 | 235 | | |
| OT828 | ABBY COCKTAIL TABLE | GY WH | 215 | 275 | | |
| OT829 | ABBY END TABLE | GY WH | 185 | 235 | | |
| OT839 | LINEAR COCKTAIL TABLE | STEEL | 225 | 285 | | |
| OT840 | LINEAR END TABLE | STEEL | 195 | 245 | | |
| OT843 | SPA COCKTAIL TABLE | GL | 225 | 285 | | |
| OT844 | SPA END TABLE | GL | 195 | 245 | | |
| OT855 | SQ KLUB COCKTAIL TABLE | WH | 225 | 285 | | |
| OT855 | REC KLUB COCKTAIL TABLE | WH | 225 | 285 | | |

| ITEM # | DESCRIPTION | COLOR | DISC | REG | QTY | TOTAL |
|---------------------|--------------------------|-------|------|-----|-----|-------|
| EXTRAS | | | | | | |
| | | | \$ | \$ | | |
| OT856 | KLUB END TABLE | WH | 195 | 245 | | |
| OT857 | KLUB SOFA TABLE | WH | 235 | 300 | | |
| OT858 | KAI COCKTAIL TABLE | BK | 225 | 285 | | |
| OT859 | KAI END TABLE | BK | 195 | 245 | | |
| OT860 | FIJI COCKTAIL TABLE | GL | 225 | 290 | | |
| OT861 | FIJI END TABLE | GL | 195 | 245 | | |
| OT863 | LOGAN COCKTAIL TABLE | WL BK | 235 | 295 | | |
| OT864 | LOGAN END TABLE | WL BK | 205 | 255 | | |
| XT199 | FOLDING CHAIR | BK | 60 | 70 | | |
| XT900 | REFRIGERATOR 4.1 CF | | 315 | 385 | | |
| XT904 | TENSA BARRIER | ST | 90 | 110 | | |
| XT905 | STANCHION | CH | 60 | 70 | | |
| XT906 | VELOUR ROPE | BK RD | 45 | 55 | | |
| XT907 | SIGN HOLDER | CH | 120 | 155 | | |
| XT908 | BAG STAND | SL | 95 | 120 | | |
| XT909 | WATERFALL CLOTHES RACK | AL | 105 | 130 | | |
| XT910 | COAT TREE | ST | 90 | 115 | | |
| XT911 | WASTEBASKET | BK | 50 | 60 | | |
| XT913 | 6 POCKET LIT RACK | BK | 170 | 210 | | |
| XT914 | WIRE 10 POCKET LIT RACK | SL | 170 | 210 | | |
| XT915 | CURVED 6 POCKET LIT RACK | SL | 190 | 240 | | |
| XT916 | COMPUTER PEDESTAL 24X42 | BK WH | 375 | 445 | | |
| XT919 | CUBE PEDESTAL | BK WH | 340 | 410 | | |
| XT922 | LAURENCE SHELF 72" H | BK WH | 225 | 285 | | |
| XT923 | METAL SHELVING 54" H | BK CH | 150 | 195 | | |
| XT924 | METAL SHELVING 72" H | BK CH | 170 | 210 | | |
| XT925 | CUBE SHELF | WH | 170 | 210 | | |
| XT926 | STELLA SHELF | BK | 225 | 290 | | |
| XT946 | BOXWOOD WALL DIVIDER | GR | 530 | 680 | | |
| XT948 | 5 TIER LOCKER | BK | 250 | 325 | | |
| XT964 | CLUB LAMP | WH | 130 | 165 | | |
| XT965 | CLUB FLOOR LAMP | WH | 190 | 240 | | |
| XT966 | SOHO LAMP | WH | 130 | 165 | | |
| XT967 | SOHO FLOOR LAMP | WH | 190 | 240 | | |
| ORDER TOTAL: | | | | | | |

Payment Information:

Please Circle Payment Type:

Company Check Enclosed Credit Card: American Express VISA MasterCard

Credit Card Number _____

Veri Code _____ Exp. Date _____

Billing Address _____

City _____ State _____ Zip _____

Authorized Signature _____

Card Holder Name _____

Company Name: _____ Phone #: _____ Email: _____

Address: _____ City: _____ State: _____ Zip: _____

Authorized By (print): _____ Signature: _____ Booth #: _____

Chairs



CH100 JACOBSON CHAIR
White
18"Wx17"Dx18"H



CH102 MONACO CHAIR
Black
23"Wx23"Dx18"H



CH103 CAZMA CHAIR
Black, Red
22"Wx22"Dx18"H



CH104 TOLEDO CHAIR
Natural/Chrome
17"Wx19"Dx18"H



CH106 CRISS CROSS
White/Chrome
17"Wx19"Dx18"H



CH107 PARIS CHAIR
White/Chrome, White/Natural
19"Wx22"Dx18"H



CH109 LIQUID CHAIR
Blue, Orange, Red, White
20"Wx18"Dx18"H

CH111 TICINO CHAIR
White
18"Wx19"Dx18"H



CH112 RETRO CHAIR
Steel
19"Wx17"Dx18"H



CH113 LESLIE CHAIR
White
19"Wx21"Dx18"H



CH114 TENDY CHAIR
Black, Walnut, White
17"Wx18"Dx18"H



CH116 BELLA CHAIR
Black, White
18"Wx20"Dx19"H



CH118 EURO CHAIR
Black, White
22"Wx21"Dx18"H



CH120 SKYE CHAIR
Clear
18"Wx18"Dx18"H



CH121 MIA CHAIR
White
23"Wx20"Dx18"H



CH124 WAVE CHAIR
Clear
19"Wx18"Dx18"H



CH125 CASPER CHAIR
Black, White
19"Wx20"Dx20"H

Furniture Collection

Bar Stools



ST202 MONACO STOOL
Black
23"Wx23"Dx30"H



ST203 EQUINO STOOL
Black, White - Adj.
14"Wx17"Dx26-30"H



ST204 TOLEDO STOOL
Natural/Chrome
19"Wx19"Dx30"H



ST206 CRISS CROSS STOOL
White/Chrome
15"Wx19"Dx29"H



ST207 PARIS STOOL
White/Chrome, White/Natural
19"Wx18"Dx30"H



ST209 LIQUID STOOL
Blue, Orange, Red, White
19"Wx20"Dx30"H



ST210 OTTO STOOL
Black, White
16"Wx18"Dx24-30"H



ST211 TICINO STOOL
White
17"Wx20"Dx30"H



ST212 RETRO STOOL
Steel
17"Wx17"Dx30"H



ST214 TENDY STOOL
Black, Walnut, White
17"Wx17"Dx30"H



ST216 BELLA STOOL
Black, White
17"Wx19"Dx30"H



ST218 EURO STOOL
Black, White - Adjustable
20"Wx17"Dx24-33"H



ST218-2 EURO 2 STOOL
Black, White
20"Wx17"Dx33"H



ST219 TECH STOOL
White - Adjustable
15"Wx15"Dx22-29"H



ST220 SKYE STOOL
Clear
19"Wx21"Dx30"H



ST221 MIA STOOL
White
20"Wx18"Dx30"H



ST223 CHLOE STOOL
Clear
17"Wx19"Dx30"H



ST222 BRAXTON STOOL
Black, White
17"Wx20"Dx29"H



ST224 WAVE STOOL
Clear
18"Wx19"Dx30"H

Furniture Collection

Café Tables



CT300 PEDESTAL TABLE
Black, White
24"Dia.x30"H



CT301 PEDESTAL TABLE
Black, White
30"Dia.x30"H



CT302 CAFE TABLE
Black, Grey, White
36"Dia.x30"H



CT303 CAFE TABLE
Black, Grey, White
42"Dia.x30"H



CT304 SQUARE CAFE TABLE
Black, White
30"Sq.x30"H



CT305 SQUARE CAFE TABLE
Black, White
36"Sq.x30"H



CT306 TRAVE TABLE
Chrome/Glass
36"Dia.x30"H (Other sizes available)



CT307 BISTRO TABLE
Black, Natural, White
30"Dia.x30"H



CT309 PARIS CAFE TABLE
White/Natural
36"Dia.x30"H



CT310 CHROMA TABLE
Aluminum
28sq.x30"H



CT311 CHROMA TABLE
Aluminum
28"Dia.x30"H



CT312 RETRO TABLE
Steel
32"Wx32"Dx30"H



CT313 MARTINI TABLE
Chrome/Glass
36"Dia.x30"H



CT314 ABBY CAFE TABLE
White
36"Wx36"Dx30"H



CT353 ALTOS TABLE
Chrome/Glass
60"Wx36"Dx30"H



CT355 ABBY TABLE
White
63"Wx36"Dx30"H



CT357 EDGE CAFE TABLE
White
72"Wx29"Dx30"H

CT357-P EDGE CAFE TABLE W/POWER
White
72"Wx29"Dx30"H

Furniture Collection

Bar Tables and Bars



BT400 / BT401 BAR PEDESTAL TABLE
Black, White
24"Dia.x42"H or 30"Dia.x42"H

BT402 BAR HIGH TABLE
Black, Grey, White
36"Dia.x42"H

BT404 / BT405 SQUARE BAR TABLE
Black, White
30"Sq.x42"H or 36"Sq.x42"H

BT406 TRAVE BAR TABLE
Chrome/Glass
32"Dia.x42"H (Other sizes available)



BT407 BRAVO BAR TABLE
Black, Natural, White
30"Dia.x42"H

BT410 CHROMA BAR TABLE
Aluminum
24"Dia.x42"H

BT412 RETRO BAR TABLE
Steel
24"Sq.x42"H



BT413 MARTINI BAR TABLE
Chrome/Glass
32"Dia.x42"H

BT450 MANHATTAN BAR
Steel
63"Wx29"Dx42"H

BT451 INFORMATION COUNTER
Black, White - Locking
48"Wx20"Dx40"H



BT454 BALI BAR
Black, White
57"Wx24"Dx40"H

BT454-P W/POWER
Black, White
57"Wx24"Dx40"H

BT457 EDGE COMMUNAL BAR TABLE
Black, White
72"Wx30"Dx42"H

BT457-P W/POWER
Black, White
72"Wx30"Dx42"H

Furniture Collection

Modular Pedestals



BT480 / BT481 / BT482 MOD CYLINDER PEDESTAL
White
21"Dia.x18"H 21"Dia.x30"H 21"Dia.x42"H



BT483 / BT484 MOD CUBE PEDESTAL
White
24"Sq.x24"H 21"Sq.x42"H



BT486 MULTI COLOR LIGHT BOX.
Order for use with BT480 Through BT485

Conference and Office Chairs



CO501 OTTO GUEST CHAIR
Black, White
23"Wx22"Dx18"H



CO502 OTTO CHAIR
Black, White
23"Wx22"Dx18-21"H



CO507 GUEST CHAIR
Black
25"Wx25"Dx18"H



CO508 MIDBACK CHAIR
Black
25"Wx24"Dx18-22"H



CO509 STACKABLE SIDE CHAIR
Black
20"Wx20"Dx18"H



CO510 STACKABLE ARM CHAIR
Black
24"Wx20"Dx18"H



CO512 TASK CHAIR
Black
19"Wx22"x18-22"H



CO513 TASK STOOL
Black, Adjustable
19"Wx22"Dx23-27"H



CO518 RECEPTION CHAIR
Black
24"Wx26"Dx36"H



CO520 ZURICH HIGHBACK CHAIR
Black, White
24"Wx24"Dx19"H

Furniture Collection

Conference Tables



CF603 CONFERENCE TABLE
Black, Cognac, Grey, Maple, White
48"Dia.x30"H



CF604 GLACIER CONFERENCE TABLE
White-Gloss
79"Wx40"Dx30"H

CF605 RECTANGULAR CONFERENCE TABLE
Black, Cognac, Maple, White
72"Wx36"Dx30"H

CF606 / CF608 CONFERENCE TABLE
Black, Grey, White
72"Wx36"Dx30"H or 96"Wx42"Dx30"H



CF609 RECTANGULAR CONFERENCE TABLE
Black, White
96"Wx42"Dx30"H



CF610 OVAL CONFERENCE TABLE
Black, White
120"Wx42"Dx30"H



CF611 RECTANGULAR CONFERENCE TABLE
Black, White
120"Wx42"Dx30"H

Additional conference table sizes, colors and power options available. Contact your sales rep for information.

Office Furniture



OF653 STORAGE CABINET
Black, White - Locking
37"Wx21"Dx29"H



OF659 STORAGE CREDENZA
White
48"Wx18"Dx33"H



OF660 GLACIER SIDEBOARD
White-Gloss
48"Wx18"Dx30"H



OF670 PARSON DESK
Grey, White
48"Wx24"Dx29"H



Furniture Collection

Lounge Seating



LG706 SCANDIC SOFA
Black, Red, White
82"Wx34"Dx30"H



LG707 SCANDIC LOVESEAT
Black, Red, White
59"Wx34"Dx30"H



LG708 SCANDIC CHAIR
Black, Red, White
38"Wx34"Dx30"H



LG709 PRATO ARM CHAIR
Black, White
29"Wx28"Dx33"H



LG710 PRATO ARMLESS SECTIONAL
Black, White
22"Wx28"Dx33"H



LG711 PRATO CORNER SECTIONAL
Black, White
32"Wx32"Dx33"H



LG712 SOLO SOFA
Black, Red
80"Wx35"Dx32"H



LG713 SOLO LOVESEAT
Black, Red
57"Wx35"Dx32"H



LG714 SOLO CHAIR
Black, Red
34"Wx35"Dx32"H



LG715 MALIBU SOFA WITH POWER
Black, White
73"Wx31"Dx30"H



LG724 MALIBU LOVESEAT WITH POWER
White
52"Wx31"Dx30"H



LG716 MALIBU CHAIR WITH POWER
Black, White
32"Wx31"Dx29"H



LG717 IBIZA CHAIR
Black, White
30"Wx33"Dx33"H



LG718 BRENTWOOD SOFA
Grey
77"Wx35"Dx34"H



LG731 SOHO CURVED BENCH
White
58"Wx22"Dx17"H



LG732 SOHO LOVESEAT
White
48"Wx24"Dx31"H



LG733 TRIBECA LEATHER SOFA
Grey
89"Wx36"Dx33"H



LG734 TRIBECA LEATHER LOVESEAT
Grey
61"Wx36"Dx33"H



LG735 TRIBECA LEATHER CHAIR
Grey
34"Wx36"Dx33"H



LG736 ASPEN SOFA
White
82"Wx31"Dx28"H



LG737 ASPEN CHAIR
White
36"Wx31"Dx28"H



LG747 ANTON CHAIR
Pearl
26"Wx33"Dx32"H



LG758 AURORA SOFA
White
81"Wx36"Dx34"H



LG762 AURORA LOVESEAT
White
59"Wx36"Dx34"H



LG759 AURORA CHAIR
White
37"Wx36"Dx34"H



LG749 TICINO SETTEE
White
48"Wx24"Dx34"H



LG750 BENCH OTTOMAN
Black, White
60"Wx20"Dx17"H



LG753 ROUND SWIVEL OTTOMAN
Black, Orange, White
18" Dia.x17"H



LG755 BLOCK OTTOMAN
Blue Microfiber, Black, Red, White Leatherette
18"Wx18"Dx18"H



LG757 RECTANGLE OTTOMAN
Black, White Leatherette
36"Wx18"Dx18"H



LG763 JAVA BENCH
Natural
72"Wx18"Dx15"H



LG780 STEN SWIVEL CHAIR
Black, Red, White
32"Wx32"Dx29"H



LG784 AVA CHAIR
White
22"Wx22"Dx19"H



LG785 LARGO CHAIR
White
30"Wx26"Dx28"H



LG786 SWAN CHAIR
Black, White
29"Wx28"Dx35"H

Furniture Collection

Occasional Tables



OT804 TUSCAN COCKTAIL TABLE
Teak
48"Wx21"Dx16"H



OT805 TUSCAN END TABLE
Teak
18"Wx18"Dx18"H



OT808 VAIL COCKTAIL TABLE
Glass
48"Wx28"Dx17"H



OT809 VAIL END TABLE
Glass
19.5"Wx19.5"Dx21"H



OT810 BELLO COCKTAIL TABLE
White
47"Wx27"Dx16"H



OT811 BELLO END TABLE
White
24"Wx22"H



OT817 KEMI COCKTAIL TABLE
Chrome/Glass
48"Wx24"Dx16"H



OT818 KEMI END TABLE
Chrome/Glass
22"Wx22"Dx22"H



OT821 VEGA TABLE 18" DIA.
Black, Blue, Green, Red, White, Yellow - Adjustable
18"Dia.x19-31"H



OT823 VORTEX TABLE
White, Black
16"Wx16"Dx17"H



OT824 VENTURA COFFEE TABLE
Steel/Walnut
48"Wx24"Dx16"H



OT825 VENTURA END TABLE
Steel/Walnut
24"Wx24"Dx18"H



OT826 CRYSTAL COCKTAIL TABLE
Glass
48"Wx24"Dx19"H



OT827 CRYSTAL END TABLE
Glass
24"Wx24"Dx24"H



OT828 ABBY COCKTAIL TABLE
Grey, White
48"Wx24"Dx14"H



OT829 ABBY END TABLE
Grey, White
24"Wx24"Dx20"H



OT839 LINEAR COCKTAIL TABLE
Steel
46"Wx15"Dx16"H

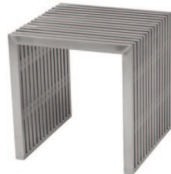

OT840 LINEAR END TABLE
Steel
15"Wx15"Dx16"H



OT843 SPA COCKTAIL TABLE
Silver/Glass
36"Dia.x18"H



OT844 SPA END TABLE
Silver/Glass
24"Dia.x24"H



OT855 SQ KLUB COCKTAIL TBL.
White
36"Wx36"Dx15"H



OT855 REC KLUB COCKTAIL TBL.
White
48"Wx24"Dx16"H



OT856 KLUB END TBL.
White
24"Wx24"Dx18"H



OT857 KLUB SOFA TABLE
White
36"Wx10"Dx30"H



OT858 KAI COCKTAIL TABLE
Black/Glass
40"Wx36"Dx15"H



OT859 KAI END TABLE
Black/Glass
26"Dia.x22"H



OT860 FIJI COCKTAIL TABLE
Chrome/Glass
36"Dia.x17"H



OT861 FIJI END TABLE
Chrome/Glass
20"Dia.x23"H



OT863 LOGAN COCKTAIL TABLE
Walnut, Black
47"Wx24"Dx16"H



OT864 LOGAN END TABLE
Walnut, Black
22"Wx22"Dx22"H

Furniture Collection

Extras



XT199 FOLDING CHAIR
Black
19"Wx20"Dx18"H



XT900 REFRIGERATOR 4.1 CF
17"Wx20"Dx32"H



XT904 TENSA BARRIER
Chrome/Black
72"Wx38"H



XT905 CHROME STANCHION/ XT906 ROPE
Black, Red
12"Wx39"H rope 6'



XT907 SIGN HOLDER
Chrome
22"Wx28"H



XT908 BAG STAND
Silver
40"H



XT909 WATERFALL STAND
Chrome - Adjustable
48"-72"H



XT910 COAT TREE
Steel
13"Wx69"H



XT911 WASTEBASKET
Black
10"Wx24"H



XT913 6-POCKET LIT. RACK
Black
60"H



XT914 WIRE 10-POCKET LIT. RACK
Silver
11"Wx14"Dx54"H



XT915 CURVED 6-POCKET LIT. RACK
Silver
15"Wx15"Dx50"H



XT916 COMPUTER PEDESTAL
Black, White - Locking
24"Wx24"Dx42"H



XT919 CUBE PEDESTAL
Black, White
24"Wx24"Dx42"H

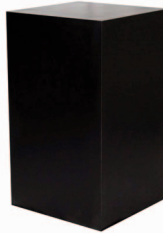

XT922 LAURENCE SHELF
Black, White
35"Wx15"Dx68"H



XT923/XT924 METAL SHELVING
Black, Chrome
36"Wx14"Dx54"H or 36"Wx18"Dx72"H



XT925 CUBE SHELF
White
31"Wx15"Dx58"H



XT926 STELLA SHELF
Black
36"Wx14"Dx72"H



XT946 BOXWOOD WALL DIVIDER
Green
48"Wx16"Dx48"H



XT948 5 TIER LOCKER
Black
15"Wx18"Dx66"H



XT964 CLUB LAMP
White/Chrome
17"Wx28"H



XT965 CLUB FLOOR LAMP
White/Chrome
19"Wx61"H



XT966 SOHO LAMP
White
12"Wx23"H



XT967 SOHO FLOOR LAMP
White
18"Wx60"H



EXHIBITOR KIT

Facility Contact Information

| | | |
|--|--------------|-------------------|
| Convention Services | 702 892-2860 | Fax: 702 892-2933 |
| Food & Beverage Services (Operated by Sodexo! Live) | 702 943-6779 | Fax: 702 943-6782 |
| COX Business | 702 943-6500 | |
| FedEx | 702 943-6780 | |
| Safety and Fire Prevention Office | 702 892-7413 | |
| Customer Safety Department | 702 892-7400 | |

Code of Conduct

- **SAFETY FIRST** – Follow all safety guidelines and instructions. Report any hazards or unsafe behaviors to LVCC staff immediately.
- **RESPECT AND COURTESY** - Treat all building occupants with respect, regardless of their role, background, or beliefs. Avoid language that is offensive, discriminatory, or harmful.
- **ZERO-TOLERANCE POLICY** – Any form of discrimination, harassment, or bullying, whether based on race, gender, age, disability, national origin, religion, or sexual orientation, will result in immediate removal.
- **REPORTING CONCERNS** – Visitors should report any issues or concerns to convention center staff. If you see something that violates this code, report it to LVCVA Security personnel at (702) 892-7400.
- **PROFESSIONAL BEHAVIOR** – All people, whether LVCC employees, visitors, or non-LVCC workers, are expected to always conduct themselves professionally and respectfully. Please refrain from casual or inappropriate conversations and behavior.
- **APPROPRIATE ATTIRE** – Wear appropriate attire while on LVCVA property, this includes but not limited to: pants/shorts, shoes, and shirts must be always worn.
- **ALCOHOL AND DRUGS** – The consumption of alcohol is permitted only in designated areas. The use or possession of illegal drugs is strictly prohibited.
- **CLEANLINESS** – Keep the venue clean. Use the provided trash receptacles and recycling bins. Workers should ensure their respective areas are clean and organized.
- **PRIVACY AND PHOTOGRAPHY** – Ask for permission before taking photographs or videos of individuals or property. Respect privacy requests as well as event rules/regulations. Workers should not share confidential information or images without permission.
- **COMPLIANCE WITH LAW** – All building patrons, regardless of purpose on LVCVA property, must adhere to local, state, and federal laws while at the convention center.
- **PROHIBITED ITEMS** – The possession of unauthorized items, including but not limited to, weapons, drugs, and property, is strictly forbidden and will result in immediate removal from the LVCC.
- **NO UNAUTHORIZED ACCESS** – Entry into restricted areas without proper clearance will result in immediate removal and potential legal action.
- **MANDATORY IDENTIFICATION** – Event badges or proper company/union identification must be visibly displayed while on LVCC property. Failure to present IDs when asked will result in removal from the premises.
- **RESPECT FOR PROPERTY** – Any form of vandalism, theft, or misuse of property will result in immediate removal and potential legal action.
- **PROPERTY REMOVAL** – No individual is allowed to remove any property, materials, equipment, or items belonging to the convention center or any events occurring on LVCC premises without show management approval. Violators will be trespassed and could face potential legal action.
- **SMOKING** – Smoking indoors is prohibited. Smoking outdoors, including vaping, is not allowed on LVCC property except in designated smoking areas.
- **CONSEQUENCES FOR VIOLATIONS** – Violations of the code may result in warnings, temporary bans, or permanent removal from the LVCC campus at the discretion of the LVCVA management.
- **AMENDMENTS** – This Code of Conduct is not intended to be all-inclusive and may be updated as needed to address new challenges and ensure the well-being of the facility and its occupants.

AEROSOL CANS

- Aerosol cans containing flammable gases or liquids are prohibited. Only empty containers may be placed on display.
- Flammable liquids, solids or gases are prohibited inside the building unless prior review and approval is obtained.
- NOTE: For any questions or exemption requests, please contact your convention services manager.

ANIMALS

- Service animals are always welcome. Refer to the Americans with Disabilities Act for the definition of a service animal.
- Permission for any animal to appear in a show or booth must first be approved by show management, then by the CSM.
- It is the animal owner's responsibility to clean up after the animal while on facility property.
- Animals, except for fish, are not allowed in the building overnight.
- A separate certificate of insurance in the amount of \$1 million combined single limit bodily injury and broad-form property damage coverage, including broad-form contractual liability, naming the LVCVA as additional insured must be provided.

BALLOONS

Show management and your convention services manager (CSM) must approve the use of balloons.

Indoors

- Helium balloons, including columns and arches, must be tethered.
- Helium gas cylinders used for refilling must be secured in an upright position on ANSI-approved (American National Standards Institute) fire prevention stands with the regulators and gauges protected from potential damage.
- Overnight storage of helium or compressed air cylinders in the building is prohibited.
- Helium balloons may not be used for handouts. Blimps may not be flown around the exhibit hall.

Outdoors

Moored balloons including hot air balloons and kites, are permitted on property with the following conditions:

- Must have approval from show management and your CSM.
- Balloons/kites must be moored and can only be used for displays.
- Balloons/kites must not exceed the height of the building.
- Hot-air balloons that are inflated and standing must have an FAA-certified pilot, with a commercial rating for lighter-than-air aircraft, with the balloon always.

BOOTH SETUP

If approved by show management, an exhibitor has the option of contracting the setup of their booth or setting up the booth themselves. If an exhibitor opts to set up their own booth, the individuals doing the setup must be full-time employees of the exhibiting company and able to provide credentials. All persons must comply with the Occupational Safety and Health Administration (OSHA) safety standards.

CHEMICALS

- All chemicals brought into the facility must be labeled as required by OSHA and accompanied by the applicable safety data sheet (SDS).
- A list of chemicals, including all SDS, must be included with your booth plan submittal to boothplans@lvcva.com.
- Exhibitors are responsible for supplying show management with all chemical information brought into the facility.
- The exhibitor is responsible for the disposal of all hazardous materials. Disposal of hazardous materials is prohibited in the sinks, sewer lines and drains of the facility.
- All chemicals shall be removed from the facility at the conclusion of the show.

CONTRACTOR AND VENDOR REQUIREMENTS

- Any show appointed and/or exhibitor appointed company providing a service and/or supervision during conventions, trade shows and events at the facility must obtain an annually issued EAC permit and comply with the following:
- Annual Contractor Fee: \$250
- Certificates of Insurance (COI) — [Requirements and Sample COI](#)
- General liability in the amount of \$1,000,000 combined single limit bodily injury and broad form property damage coverage, including broad form contractual liability.
- Automobile liability in the amount of \$1,000,000 for any auto and/or hired and non-owned.
- Workers' Compensation Coverage in the state of Nevada with minimum of \$1,000,000 limit. If the home state of the contractor does not have a reciprocal agreement with the state of Nevada, contact employers to obtain proper coverage. Phone 888-682-6671 or <https://www.employers.com/>.
- Apply for [EAC permit](#).

DRONES/UNMANNED AERIAL SYSTEMS (UASS) GUIDELINES

UASs – Unmanned aerial systems includes all of the following:

- All drone/UAS operators must comply with all FAA requirements.
- UAV – Unmanned Aerial Vehicle
- RPAS – Remotely Piloted Aircraft System
- RC Model Aircraft
- Drone

UASs are allowed to be used indoors or outdoors with the following requirements:

- Exhibitors must have approval from show management.
- A [Drone form](#) must be completed and submitted.
- Drones/UASs carrying weapons are prohibited.
- Drones/UASs must weigh less than 55 pounds.
- Drones/UASs are restricted to within your defined booth space only.
- Drones/UASs are prohibited from flying overpopulated areas.

- Drones/UASs must be flown in a fully enclosed area (including ceiling) using netting, plastic or other safety measure. Tethering is not an approved safety measure. Netting should be of a flame-retardant material and must be sturdy enough to prevent the UAS from breaking or escaping the enclosure.
- Drones/UASs are prohibited from flying within 18 inches of any building structure including sprinklers.
- Regardless of purpose, (including but not limited to marketing materials and/or show content) any use of UASs/drones requires Aviation Liability Insurance of at least \$1,000,000 per occurrence and \$2,000,000 aggregate. Enclosed exhibits on the show floor are exempt from aviation insurance requirement.

Outdoor Use Without Being Fully Enclosed

- For outdoor use of a drone/UAS that is not operated within a fully enclosed area, refer to the [FAA website](#) for more information.

NOTE: For any questions or exemption requests, please contact your convention services manager.

EMERGENCIES

To report an emergency, call 702-892-7400.

- Customer safety staff is trained to handle emergency situations. The Customer Safety Department is operational 24 hours a day and becomes the communications center and command post in the event of an emergency.
- The CSM is responsible for keeping show management and OSCs informed of decisions relating to emergency events in progress.
- All emergencies should be reported to the Customer Safety Department first.
- Dialing 911 will delay the response by medical personnel who may not be able to find or get to the location of the emergency.
- To report an emergency via text message, please send to 702-505-4555.

FIRE AND SAFETY EXHIBIT GUIDELINES

- For outdoor structure Information please see [Outdoor Exhibits](#).
- All means of entrance and exit must be always free from obstruction.
- Any individuals observed blocking, taping, or propping open a door with any type of object and/or leaving the door unsecured, will be trespassed from property.
- Each hard-wall booth must be a minimum of nine inches from the booth line for access to electrical.
- No storage of any kind is allowed behind booths or near electrical service. A one-day supply of product is permitted within but cannot be stored behind the booth.
- All fire extinguishers and emergency exits must be always visible and accessible. Should this equipment be within a booth or exhibit due to the layout of floor space, additional signage indicating fire equipment location(s) (extinguisher, hoses, etc.) will be necessary, along with accessibility being always maintained.
- Exhibit booth construction shall meet the requirements. The upper deck of multilevel exhibits that is greater than 300 square feet (28 sq. m) will need at least two remote means of egress. The upper deck, if occupied, must have a live load capacity of 100 pounds per square foot. All materials used in exhibit construction, decoration or as a temporary cover must be certified as flame retardant, or a sample must be available for testing. Materials that cannot be treated to meet the requirements may not be used.
- For safety and operational efficiency, the Las Vegas Convention and Visitors Authority Fire Prevention personnel reserve the right to access and inspect all electrical components within exhibitor booths, including those integrated into prefabricated structures. This access is crucial to ensure compliance with safety regulations, identify potential hazards, and facilitate necessary maintenance or emergency procedures. Exhibitors are expected to maintain clear and unobstructed access to all electrical installations throughout the duration of the show.

- Construction and demolition of multilevel booths and exhibits require compliance with OSHA fall protection regulations for general industry requirements.
- Any single-level exhibit over 1,000 sq ft must submit a booth plan to the Safety and Fire Prevention Office for approval. Please submit plans to boothplans@lvcva.com.
- All electrical wiring must be installed per National Electrical Code® (NEC) standards.
- The Fire Prevention office will only allow exhibitors to display air compressors (without load) to show their product. All other compressor needs must be handled by an official service contractor (OSC) to ensure proper drops to exhibit booths with pneumatic products.
- Use of halogen fixtures must comply with our halogen lamp restrictions.
- If the booth contains a display with moving machinery:
 - A designated safety zone that is clearly marked where attendees should not enter, or stand shall be present.
 - If needed, physical barriers/guards are required to separate attendees from moving, spinning, pinching or crushing parts.
 - Manufacture-installed guards must remain in place and cannot be altered or removed. Please refer to the [OSHA website](#) for more information.
 - Highly visible signage indicating hazards and restricted areas.
 - Must ensure that trained staff members are present to monitor attendees and prevent unsafe behavior.
 - Machinery must be equipped with easily accessible emergency stop buttons.
 - Operational controls must be locked or out of reach of attendees to prevent unauthorized use.
 - Staff should also be trained in emergency response in case of accidents.
 - At no time should the moving parts of the machinery extend/intrude into designated aisles outside of
- When approved, LPG (propane) containers having a maximum water capacity of 12 pounds [nominal 5-pound LP-Gas capacity] may be permitted temporarily inside the convention facility for public exhibitions or demonstrations. If more than one such container is in an area, the containers shall be separated by at least 20 feet.
- Any exception to the first two requirements above must be submitted for review and approval by the Safety and Fire Prevention Office and the CSM.
- All LPG containers must be separated and inaccessible to the public. Cooking and food warming devices within exhibit booths shall be isolated from the public by not less than 48 inches (1,220 mm) or by a barrier between the devices and the public.
- The after-hours, overnight storage of any LPG container inside the convention facility is strictly prohibited. Containers must be removed at the end of each day and can be delivered back to the show floor upon the arrival of exhibit staff in the morning.
- Propane cylinders awaiting use should be stored in a secured propane storage cage that meets the requirements of OSHA. Storage cages must be secured in designated locations outside the building.
- No dispensing from or refilling of LPG containers will be permitted inside the convention facility.
- Use of LPG outdoors must be approved by the Safety and Fire Prevention Office and the CSM prior to arrival on property. No outside LPG will be permitted in any areas where building exits discharge or fire department access is required.
- When requested, areas enclosed by solid walls and ceilings must be provided with approved smoke detectors that are audible outside the area of the booth. A fire watch may be required. (See Multilevel and/or Covered Exhibits for more information.)
- The travel distance within the exhibit booth or exhibit enclosure to an exit access aisle shall not exceed 50 feet.
- A one-day supply of giveaway disposable lighters may be kept in the booth.
- Exhibitors who plan to demonstrate fuel-burning appliances on property must have approval from the CSM 30 days prior to the event.

- Fireplaces must be listed as ventless or self-venting for indoor use to obtain approval for use inside the facility.
- Only enclosed fireplaces will be approved for use, meaning the fireplace must be enclosed with a glass front, or a protective heat/contact barrier must be installed to prevent combustible exposure or attendee contact.
- Screen-front fireplaces will not be approved for use.
- Exhibit design directly around the fireplace and installation of the fireplace must meet the requirement/code for permanent fireplace installation. Distances from exposure to combustibles must meet the requirements for permanent installations.
- Fire Pits that are not fully enclosed with a glass front or a protective heat/contact barrier will require an [Open-Flame Permit](#) from Clark County Fire Department. Natural gas and approved LPG (propane) quantities will be allowed for use within the halls. A barrier is required to prevent an attendee/exhibitor from encountering an open flame.
- Please see the [Fireplace and Fire Pit Display form](#) for details on obtaining an Open Flame Permit along with the [Fire Watch Requirements form](#).
- Candles may be used for decorative purposes for events with food service (one candle per table) where the candles are supported by/on substantial noncombustible bases located to avoid danger of ignition of combustible materials. Candle flames shall be protected and enclosed so that if the candle were to tip over, there would be no risk of fire. The Safety and Fire Prevention Office has final approval to determine if a candle meets the above criteria. Candles may not be left unattended while lit.
- If your booth is demonstrating, sampling, or using a hookah, the following items are required:
- Keep a 5-pound ABC (2A:30BC) fire extinguisher at the booth. The fire extinguisher must have a current inspection tag. Extinguishers may be obtained from the show or a local company.
- Keep a metal (noncombustible) bucket for hot coals.
- The hookah must be placed on a stable, noncombustible surface (table, stand, stool, etc.). The hookah cannot be placed directly on a carpeted surface.
- Keep all combustible materials (boxes, plastics, etc.) a minimum of three feet away from the hookah.
- [Click here](#) for information regarding vehicles on display.

FLAMMABLES

Lighters, Torches, Open Flames

- The Las Vegas Convention and Visitors Authority and Clark County Fire Code prohibit flammable liquid, gasses, or solids in the Las Vegas Convention Center. Reasonable accommodations can be made for items that are for demonstration purposes.

LIGHTERS

- Storage of lighters in a booth is prohibited.
- **For demonstration:** Requires an open flame permit from Clark County Department of Building and Fire Prevention. [Clark County Permit](#)
- **For display/giveaways:** Exhibitors can keep a one-day supply of lighters in the booth, if giving away lighters to attendees.

TORCHES

- **For display:** Butane/propane torches for display must be empty of fuel.
- **For demonstration:** Requires an open flame permit from Clark County Department of Building and Fire Prevention. [Clark County Permit](#)
- REFILL CONTAINERS/CANISTERS

- Fuel refill containers on display must be empty. This includes all butane or propane refill tanks and containers of lighter fluid.
- All other flammables on display (such aerosol spray cans) must be empty display models.
- Applications for open flame permits can be submitted online [Clark County Permit](https://www.clarkcountynv.gov/permits) or by email at permits@ClarkCountyNV.gov.
- Select the box labeled Candles and Open Flames and fill out the required information prior to submitting. If you need assistance, please contact the LVCVA Safety and Fire Prevention Office for assistance, (702) 892-7413.

FOG MACHINES

- Use of all fog machines must be preapproved by the Safety and Fire Prevention Office. A demonstration of the fog machine and its intended use must be given to the office at least 48 hours in advance.
- The fog machine must be UL listed or equivalent (for its intended use).
- Fog-generating fluids must be nonhazardous and stored in the original containers that were provided by the manufacturer. The safety data sheet for fog fluid must be sent to the Safety and Fire Prevention Office for approval in advance of the event move-in.
- The SDS must always remain in the booth/event location.
- The facility reserves the right to limit the amount of haze produced by a show. Must provide a haze schedule including days for testing and show hours 30 days prior to first day of use. After hours haze activity requires coordination with third party vendor. Fees will apply.

FOOD AND BEVERAGE

Las Vegas Food & Beverage retains the exclusive right to provide, control and retain all food and beverage services within the LVCC. Outside food and beverage are not permitted without prior approval. Fees may apply.

Preparation Within Exhibits

Whenever food or beverage is prepared within an exhibit, a [Food and Beverage Sampling/Onsite Preparation Approval Form](#) must be completed and emailed to foodprepandsample@lvcva.com. Approval from both LVCVA and the Food & Beverage Division must be received prior to finalizing your plans.

Exhibition and Display Cooking

Temporary exhibition and display cooking are only permitted within the limitations given below.

- All cooking appliances shall be listed or approved by a nationally recognized testing agency, e.g., Underwriters Laboratories, Inc., American Gas Association.
- All cooking equipment is to be operated according to the manufacturer's operating instructions. Equipment listed or designed for outdoor use shall not be used indoors.
- All multiple-well cooking equipment using combustible oils or solids and cooking surfaces, i.e., grills that exceed 288 square inches (2 square feet) that produce grease-laden vapors, must have a fire-extinguishing system installed and an exhaust duct system complying with the currently adopted Mechanical Code.
- All single-well cooking equipment (deep-fat fryers) and operations using combustible oils or solids shall meet all the following criteria:
 - Metal lids sized to cover the horizontal cooking surface are to be provided.
 - The cooking surface is limited to 288 square inches (2 square feet).
 - The equipment shall be placed on a noncombustible or limited combustible surface. Examples include concrete floors and fire-retardant-treated (FRT) plywood. The noncombustible surface must extend three feet in front of the fryer.
 - The fryer is to be separated from all other equipment by a distance not less than 24 inches.

- These cooking displays must be separated from all other combustibles by a distance not less than 10 feet.
 - The volume of cooking oil per appliance is not to exceed three gallons.
 - The volume of cooking oil per booth is not to exceed six gallons.
 - Deep-fat fryers shall be electrically powered and have a shut-off switch.
 - Fry oil must be collected and disposed of by a third-party vendor hired by the lessee.
- Other appliances for exhibition cooking shall also be limited to 288 square inches (2 square feet) in area. Examples: induction cooktops, ranges, electric warmer, single- ranges or multiple- burner ranges.
 - A minimum of one Class-K fire extinguisher shall be located within 30 feet of each deep-fat fryer and each grill or other appliance producing grease-laden vapors.
 - A minimum of one Class 3A-40BC fire extinguisher shall be located within each booth with additional or other display cooking, such as baking, sautéing, braising, stir frying, convection cooking, warming of food, and all other like applications.
 - Solid fuels, including charcoal and woods, are prohibited within exhibit halls.

NOTE: For any questions or exemption requests, please contact your convention services manager.

Food Sampling Information

The Southern Nevada Health District enforces regulations for the sampling of food during trade shows.

A [Food and Beverage Sampling/Onsite Preparation Approval Form](#) must be completed and emailed to foodprepandsample@lvcva.com by exhibitors who are giving away free food or beverage. Approval from both the LVCVA and the Food & Beverage Division must be received prior to finalizing your plans.

Once the form has been submitted, a member of the Las Vegas Food & Beverage management team will contact you.

- All items to be given away are limited to sample sizes.
- Nonalcoholic beverages: 3 oz.
- Food items: 2 oz.
- Any food or beverage items not directly manufactured by the exhibitor must be purchased from and supplied by our exclusive food and beverage provider.
- If sampling of open food or beverage is conducted at a booth, then both a hot-water hand- washing station and a sanitizing station will be required.
- Handwashing and sanitization stations may be purchased through the food and beverage division or provided by the exhibitor. If provided by the exhibitor, contact the [Southern Nevada Health District](#).
- Hot water for handwashing will be provided. Hot-water refill station(s) will be available on the show floor. Check with show management for the location(s).
- If any alcoholic beverages are to be served, exhibitors must contact our Food & Beverage Division for approval and follow the Nevada Department of Taxation guidelines regarding liquor at trade shows. All alcoholic beverages must be served by our bartenders/servers who are TAM certified. Some exceptions may apply.

If you have any questions, contact the LVCVA's Food & Beverage Division at 702-943-6779 or email exhibitorcateringlvcc@sodexo.com.

GAMING/RAFFLES

- For raffle/gaming inquiries, please contact the [Nevada State Gaming Control Board](#) or at 702-486-2020.

HALOGEN LAMP RESTRICTIONS

The use of stem or track-mounted halogen light fixtures is not allowed unless items meet the following requirements:

- Must use a self-shielded bulb.
- Bulb wattage must not exceed the listed wattage permitted by the fixture manufacturer.
- Wattage may not exceed 75 watts.

HAND CARRY

As a customer of the Las Vegas Convention Center, (LVCC), we want to make you aware of our Hand Carry Policy. For those of you who drive to the event and wish to unload your product/materials and bring them to your booth, please be aware of the following procedures.

Exhibitors may hand carry their own materials into the exhibit space, provided they do not use material-handling equipment to assist them. Any labor used to hand carry must be performed by full-time company employees, and they must be prepared to show proof of employment.

Parking for loading/unloading must be performed from parking lots only. Curbside loading/unloading is prohibited. Parking on LVCC roadways is prohibited, and any unattended vehicles will be towed at the owner's expense. Only pickups or passenger vans will be allowed to park in LVCC parking lots for hand carry purposes. Any vehicles parked in the lots for hand carry are required to be personally owned vehicles; rentals are not allowed in the lots. Vehicles larger than pickups, vans or vehicles with trailers, must use the show's contractor for freight unloading. See the following examples of vehicles allowed/not allowed:



Escalators will no longer be allowed to move hand carry materials, and all boxes and suitcases will need to use the available elevators without the use of freight moving equipment.

Approved for Hand Carry use:

- Lightweight luggage carts.
- Hanging garment racks for moving hanging garments ONLY.
- Pop-up displays in rolling cases.



Not allowed for Hand Carry use:

- Hand carts, hand trucks, pallet jacks or any four-wheel cart or dolly.
- Access to the loading dock and/or freight doors.
- Any freight that cannot be hand carried by one person.

- Any freight moved by a moving or freight company, contractor, or any persons other than full-time employees of the exhibiting company.



- It is show management's responsibility to ensure that the hand carry policy is enforced. This includes but is not limited to managing oversized vehicles in the parking lots and equipment compliance for hand carry use.

MEETING ROOMS

- Carpeting/flooring can be placed on top of building carpet in the meeting rooms with permission from the CSM (CSM). Visqueen must be used between the building carpet and the carpet being installed. Use only nonresidue tape.
- When moving freight or equipment in these areas, carpet must be protected using Visqueen. Forklifts and electric carts are not permitted on the second or third floor. All freight and materials must be moved via pallet jack or handcart by the OSC.
- Exhibitor crates and pallets must be placed on Visqueen.
- Nothing may be affixed to meeting room ceilings, walls, or doors.
- Structures erected in meeting rooms may not have any type of ceiling. Exceptions to this are West Hall flex rooms as follows: W102-W110, W203-W212, W228-W233, W303-W310 and W322-W327.
- All structures must be at least 18 inches below fire sprinkler heads.
- Fire extinguishers, exit signs or exits may not be blocked or obstructed.
- Meeting rooms used for exhibits must have approved floor plans. Submit all plans to boothplans@lvcva.com.
- Closets in meeting rooms are for LVCVA use only.
- Meeting-room air walls will be moved only by LVCVA staff. Air walls must be configured prior to laying any type of temporary flooring over building carpet.
- Electrical service is limited to installed plugs/Crouse-Hinds show power receptacles and floor boxes in each room. (See below for listing of available show power.)

Cables and wires must be routed above doorways – not across the threshold.

Meeting Room Equipment & Guidelines

- **Amenities:** The LVCC does not provide note pads, pens, or water/water bubblers. Note: There are water-dispenser stations available throughout the facility.
- **Audio/visual equipment:** All projectors, screens, computers, tablets, phone audio adapters, etc., are to be ordered through the audio/visual contractor.
- **Audio/sound operator:** Six-channel audio mixers patched to overhead speakers in North, Central and South halls are provided, to the extent of our inventory, unless other arrangements are made. West Hall meeting rooms have virtual mixers via a Crestron wall control panel, up to four audio lines. Note: If microphone/audio input count exceeds four in a single room, the AV contractor is to provide an operator.
- **Bleachers/tiered seating:** Please contact your CSM for details.
- **Bottled water:** The LVCC will provide complimentary bottled water at head table or lectern for session/meeting rooms only or upon request based on the quantity/location requested.
- **Chairs:** The LVCC has one style of chair, which are molded plastic in gray, 20 inches by 20 inch stackable-style chair and available for meeting room sets to the extent of our inventory.

- **Draped/skirted tables:** If a draped head table or skirted table is required, it must be ordered from the service contractor or arranged with catering directly.
- **Easels:** The LVCC can provide easels to the extent of our inventory.
 - **Note:** *Easels are tripod style, not flip chart style.*
- **Electrical:** If there are electrical requirements (other than a 110 outlet) you must order through the electrical contractor. This includes any extension cords.
- **Exhibitor rooms:** Exhibitors utilizing meeting rooms for suites/custom builds are to make all arrangements including cleaning services through the OSC. Note: Rooms that are subleased for meetings are subject to additional costs.
- **Food and beverage setup:** The convention center team places tables for any food and beverage functions served by Las Vegas Food & Beverage in meeting rooms and lobbies.
 - **Note:** *Unless for a show management event on the show floor, all tables for exhibitor events on the convention show floor must be ordered through the OSC.*
- **Flip charts/markers/pointers:** Flip charts, markers and pointers are to be provided by the AV contractor.
- **Lecterns/microphones:** A standing lectern and wired microphones are provided on a complimentary basis. Equipment provided to the extent of our inventory. Wireless microphones must be ordered from the AV contractor.
- **Meeting room keys:** Up to five meeting-room key cards/metal keys/fobs can be issued per room. Multiple rooms can be programmed to one specific key (excluding metal keys). Note: Metal keys will be issued for all Central meeting rooms and N101 through N251. Key cards will be issued for all South meeting rooms, and N253 through N264. Key fobs will be issued for all West meeting rooms. Note: Metal keys and key fobs are chargeable at \$20 per unreturned key/fob.
- **Meeting room refresh:** Mid-day room refresh(es) will be conducted for education sessions/ meeting rooms only. Room refresh consists of emptying trash cans, removing any trash from tables, replenishing bottled waters at head table/lectern, straightening chairs/tables, disinfecting high-touch surfaces, and sweeping carpeted area as needed. Upon conclusion of the day/evening activity, all eligible rooms will receive a room refresh.
 - **Note:** *Rooms with food and beverage will be serviced by the catering team.*
- **Staging:** The LVCC offers risers for a stage/dais if required. Risers are 4 feet by 8 feet and stage heights are 16, 24 and 32 inches. For larger stages, heights begin at 36 inches to 54 inches. The platform is two-sided. One side is carpet in a multipattern of black, gray and white. The other is a black vinyl. Steps and black skirting are included. Safety railing is required over 32 inches high.
- **Tables:** The LVCC table options are as follows: 8 feet by 18 inches, 8 feet by 30 inches, and 6-foot rounds. The tops are gray, plastic molded and set uncovered.
- **Trash containers:** The LVCC places 40-gallon waste containers in the meeting rooms. If you require smaller trash cans, you may order from the OSC, who is also responsible for the emptying. Note: Excessive trash, e.g., swag bags/registration/giveaways, etc., to be cleaned by contract cleaners.
- **Service contractor/I&D Company rooms:** Rooms that will have a custom/special set provided by a service contractor or I&D Company are responsible for all their equipment and cleaning.
- **Walls:** The LVCC prohibits adhesive backing materials to be placed on any painted surface or walls, clings preferred. If items are attached on walls, doors, glass, it is the OSC/show organizers' responsibility to remove at the conclusion of the show or there may be a charge-back to the lessee invoice for cleaning.

Show Power in Meeting Rooms

[Click here](#) to view list of show power in meeting rooms.

MULTILEVEL AND/OR COVERED EXHIBITS (INDOOR)

- See next section for [Multilevel and/or Covered Exhibits \(Outdoor\)](#).
- It is the responsibility of the EAC and anyone erecting a structure to ensure that all rules within this section are followed. The EAC has the responsibility to work with the client to ensure booth plans, as required by this

section, are submitted to the Safety and Fire Prevention Office no later than 30 days before the first day of move-in for the event. Plans used for prior shows must be resubmitted for approval each time for the upcoming show.

- Multilevel or covered areas – Definitions:
 - **Multilevel** – Any occupied second story or greater, which is accessible by an approved means of egress.
 - **Covered Area** – Any area that covers the exhibit space and prevents the building fire sprinkler system from discharging water unobstructed to the floor. This will include single-story exhibits with ceilings, upper-deck exhibits, roof, overhead lighting installations, and any materials hanging or installed overhead that are not recognized as acceptable for use under fire sprinkler systems by fire code.
 - **Means of Egress** – An approved stairway or ramp constructed to the specifications of the code used for access and exiting.
- Multilevel or covered contiguous areas more than 1,000 square feet are required to have a fire sprinkler system installed under the entire area and every level of the exhibit only when the following conditions apply:
 - The exhibit is used in an event where the duration is seven calendar days or longer.
 - The exhibit contains display vehicles.
 - The exhibit contains open flame.
 - The exhibit contains hot work.
- Any upper-deck area to be occupied must have an approved plan with an engineer stamp registered in the state of Nevada.
- Multilevel areas that are greater than 300 square feet or will occupy more than nine persons shall have at least two remote means of egress.
- Means of egress shall be of an approved type and constructed to the requirement of the code.
- Spiral stairs are not allowed. Spiral stairways are not an approved means of egress for areas occupied by the public, visitors or clientele. Exception: Areas less than 250 square feet shall have a 6 3/4-inch minimum clear tread depth at point 12 inches from the narrow edge. The riser shall be sufficient to provide a headroom of 78 inches minimum, but riser height shall not be more than 9 1/2 inches. Minimum stairway clear width at and below the handrail shall be 26 inches.
- Exhibits with multilevel or covered areas exceeding 300 square feet in size will require the installation of battery-operated smoke detectors. Any covered area that is also enclosed will require the installation of battery-operated smoke detectors regardless of the size of the area. All smoke detectors will emit an audible alarm that can be heard outside of the area.
- Any single-level exhibit over 1,000 square feet or exceeding 300 square feet of contiguous covered area (see “covered area” definition above) and all multiple-level exhibits must submit a booth plan to the Safety and Fire Prevention Office for approval. Plans must be submitted in CAD format via email to boothplans@lvcva.com.
- Under certain circumstances, it may be deemed necessary by the Safety and Fire Prevention Office to require a fire watch for an exhibit.

NOTE: For any questions or exemption requests, please contact your convention services manager.

MULTI-LEVEL AND/OR COVERED EXHIBITS (OUTDOOR)

All outdoor exhibits are subject to Clark County Building and Fire Codes. It is the responsibility of the exhibitor EAC to ensure all codes are met pursuant to Clark County Code sections 22.02 and 22.04, and Clark County Fire Code section 13.04.

- Clark County Fire permit is required when any temporary structure footprint is greater than 2,500 square feet and is constructed outdoors. Drawings prepared by a Nevada registered design professional and third-party inspections by a licensed AB contractor from the state of Nevada will be required for the permit.

- Any multi-level structure that is constructed outdoors, including structures less than 2,500 sq ft, will require drawings prepared by a Nevada registered design professional and a third-party inspection done by a licensed AB contractor from the state of Nevada.
- Parking lots used for exhibits that will have tents, pavilions, trailers or sprung structures must have a 24-foot perimeter aisle for fire and emergency vehicle access.
- Outdoor exhibits must have an approved floor plan. Booths that have tents, pavilions, trailers or sprung structures must be on a 10-foot-wide aisle.
- Temporary restroom facilities may be required for outdoor exhibits.
- Open trash containers/boxes are required when parking lots are used for exhibits. If containers are ordered through the facility, lessee will incur trash removal charges.
- For any **temporary assembly structures** see **Tents and Canopies** below.
- All banner material used outside must be made of mesh material with a minimum of 30% pass through or slatted to allow for air to flow through.
- Installation and dismantling of tower cranes require a 300-foot clear zone. All tower cranes require FAA approval.
- If pouring a subfloor made of concrete onto the asphalt, Visqueen must be used under the pour and the surrounding area. Bonding agents are prohibited.
- All other poured concrete requiring framework (curbing, walls, etc.) will use 16 penny nails with wire to mount and secure all batter board, bracing, etc., in asphalted areas. Square, round or other standard stakes are not permitted to secure framework in asphalted areas. Mechanical forms are preferred. LVCVA exterior engineers are available for clarification.
- Reference Food & Beverage - Preparation Within Exhibits (p. 24) for information on exhibition and display cooking.
- Reference Fire and Safety Exhibit Guidelines for information on propane usage and storage.
- Any fuel storage greater than 10 gallons of gasoline or 60 gallons of combustible liquid (e.g., diesel) on property will require a [Clark County Permit](#).
- Any exterior water use during shows will be metered. Please contact the CSM for coordination.
- LVCVA management reserves the right to make any changes on site that are deemed necessary without advance notice, for safety concerns.

Tents and Canopies

All outdoor tents and/or temporary structures must be installed by facility approved EACs and must submit and receive an approved staking plan before staking can occur. Staking plans should be submitted 30 days prior to staking@lvcva.com.

- All tents (a structure that is covered with a soft top and soft sides) greater than 400 square feet require a [Clark County Permit](#). They must also have a 2A40BC fire extinguisher that has a current Nevada state inspection tag.
- Smoke alarms are required in all tents, membrane structures, and fully enclosed areas. Smoke alarms may be battery-operated and must be installed in accordance with NFPA 72 guidelines. It is the responsibility of the individual or organization setting up the tent, membrane structure, of fully enclosed area to ensure to ensure that the required smoke alarms are installed and properly maintained.
- Smoking shall not be permitted in any tents, canopies, or temporary membrane structures.
- Approved "NO SMOKING" signs must be conspicuously posted within these structures.
- All canopies (covered with a soft top but no sides) greater than 700 square feet require a [Clark County Permit](#). They must also have a 2A40BC fire extinguisher that has a current Nevada state inspection tag.
- Self-installed pop-up canopies requiring either weights or stakes must be lowered every evening at close of show and, depending on weather conditions, may need to be taken down; to be determined by facility on site.

Staking

- All staking needs to be drilled; no hand staking is permitted.
- Anchoring or staking into concrete is prohibited property wide.
- Trenching or digging is not allowed into the asphalt without the prior approval from a CSM; please contact staking@lvcva.com for approval.
- Final on-site staking approval must be obtained by the Facility Maintenance Department before any drilling and staking may begin.
- The asphalt must be returned to its original condition. LVCVA standards are:
 - Backfill existing hole(s) with clean, fine-type sand. Tamp to within a four-inch minimum of grade surface.
 - Fill rest of hole(s) with Aquaphalt® or equivalent and tamp until solid.
 - Cover areas approximately two inches around patched hole with a good grade of plastic- type asphalt sealer with a maximum drying time of two hours.
- Staking in Orange lot is limited and strictly enforced.
- West Hall – All staking will not exceed 40 inches in depth. If additional anchoring is necessary, weights will be required.
- Staking in Yellow lot is prohibited.

TRUSS STRUCTURES

- All truss structures require plans to be submitted to Safety and Fire Prevention 90 days in advance and must meet ANSI regulations E-1.21. Depending on size, attachments and weight, the facility may require a third-party engineer's stamp of approval. The engineer's stamp of approval must include wind load and seismic load. This will be at the exhibitor's expense. Please send to boothplans@lvcva.com.
- If an exhibitor(s) has their own ballast (weight), but it is deemed insufficient by the facility, they must procure additional ballast from a local source and/or the show's OSC at their own expense.

PARKING

- The current parking fee is \$15 per space, with in and out privileges. Cash or credit cards are accepted. Anyone leaving the property and planning to return the same day can show their paid parking receipt for reentry. Reentry is subject to availability.
- Vehicles taking up more than one standard parking space will be charged accordingly upon entry.
- Overnight parking is prohibited on property. Vehicles left on the property overnight will be towed at the owner's expense.
- Vehicles must fit within two parking spaces, lengthwise.
- Individuals with special parking situations or concerns should inquire at the Traffic Office for assistance at 702-892-7400.
- All parking attendants and traffic control personnel will be provided by the LVCVA for standard traffic operations.
- Vehicles must be parked in a marked parking space.
- Paid parking dates are determined by building activity. If other shows are in the building at the same time, paid parking could be in effect during your move-in/move-out period. Check with your CSM for paid parking dates.
- Your CSM will provide 15 complimentary show staff parking passes.

PERMITS

For assistance with Clark County Building and Fire Prevention permitting, contact the Safety and Fire Prevention Office at 702-892-7413 or boothplans@lvcva.com.

Permits from Clark County Building and Fire Prevention are required for the following:

- Temporary outdoor tents and membrane structures over 400 square feet
- Canopies with a footprint greater than 700 square feet
- Hot works
- Spray and dipping booths
- Cryogenic fluids
- Compressed gases
- Mobile fueling of vehicles/fuel storage
- Open flames and candles not used for food warming
- Open-flame torches
- Flame effects and pyrotechnics
- Carnivals
- Outdoor, multi-level structures
- Outdoor structures over 2,500 square feet
- Structures with occupancy of more than 1,000
- Structure is connected to and received structural support from an existing building

Clark County Building and Fire Prevention also provides blanket permits for multiple exhibitors applying for the same permit at the same show for: hot works, spray and dipping booths, cryogenic fluids, and compressed gases. A blanket permit must be submitted to Clark County Building and Fire Prevention office by show management. [Click here](#) for more information.

PERSONAL MOBILITY DEVICES

Notice: Personal Mobility Devices Not Allowed on Property

Please be advised that only ADA-approved personal mobile devices are permitted on the premises. This policy is in place to ensure the safety and accessibility of all individuals within our facility. We kindly ask attendees to refrain from bringing any non-ADA personal mobility devices onto the property. This includes, but is not limited to, the following:

- Segways
- Manual Scooters
- Electric Scooters
- Skateboards
- Other Personal Mobility Devices

The speed limit for approved ADA personal mobility devices on the Las Vegas Convention Center property is always 5 miles per hour (mph) and electrical charging of any kind for personal mobility devices is not permitted indoors at any time. Charging is only permitted outside in designated areas.

Violation of this policy could result in being removed and trespassed from the Las Vegas Convention Center property.

We recognize the importance of providing an inclusive environment for all guests and contractors. Thank you for your cooperation and understanding in upholding this policy.

Violation of this policy will include the following punitive actions:

- 1st Violation Verbal warning**
- 2nd Violation Required to depart LVCC property for that day**
- 3rd Violation Trespass indefinitely**

Note: There are no storage spaces available for ADA-required personal mobility devices on the Las Vegas Convention Center property.

Examples of prohibited devices:



ROOF ACCESS

- Anyone requiring roof access must obtain approval in advance. To do so, submit a [roof access form](mailto:conventionservices@lvccva.com) to conventionservices@lvccva.com.
- Once written approval has been given, go to the Facility Support office (near freight door 12) on the specified installation date to complete the process.
- Roof access is by appointment only. Standard appointment times are available seven days a week between the hours of 7:30 a.m. to 3:30 p.m.
- A current driver's license or valid state ID, ESCA/WIS ID, or trade union badge must be surrendered before any pass is issued.
- Facility Maintenance staff will escort persons desiring roof access and unlock the associated roof hatch.
- Items placed on the roof must bear the contractor's name, booth number and show name.
- Anyone accessing the roof without a pass will be trespassed.
- Access to the roof areas via lift is restricted to designated areas and must have prior approval from Facility Maintenance.
- Fall protection must be used when required by OSHA.
- Foot traffic over roof surfaces must be via mats where provided.
- Penetration of the roof surface is prohibited.
- Disconnecting of roof drains for any reason is prohibited.
- Show-related equipment must be removed during move-out of the show.
- Individuals blocking or taping open any roof access doors will be trespassed from property.
- Satellite pads are available on the roof of halls C1-C5, N1-N4, and S3-S4.
- Roof access passes expire at the end of each day. No work is permitted on the roof during inclement weather or after dark.

West Hall Only

- Roof access is limited to installation of satellite/antenna installation. Two designated loading platforms are available, and roof access will only be authorized for the roof hatch immediately below the loading platforms. Those granted roof access must remain on the loading platforms; anyone found outside of the platforms will be trespassing. The access is via a fixed, 90-degree ladder. All cabling/wiring will be routed via only the designed and installed roof penetrations, no cabling/wiring will run through the roof access door, and no cabling/wiring can run across the roof from one platform to the other. Once loading platforms are determined to be at maximum use, no additional roof access will be granted.

Satellite/Antenna Installation

- Equipment installation requires [roof access form](#).
- Cox Business has exclusive rights for all cable runs.
- All satellite dishes must be placed on a three-quarter-inch carpeted piece of plywood.
- Equipment can only be mounted on roof platforms, and not on any other roof surface.
- The mounting of equipment on antenna masts is permissible where available. Contact your CSM for further information.
- Roof walkways must be used when available.
- Satellite dish size is restricted to 39 inches, with no exceptions.
- Installer is responsible for removal of satellite and any debris after the show or event concludes.
- The use of sandbags or cinder blocks is prohibited.
- Cable may not be laid through roof hatches.
- Aluminum-clad, flooded, jacketed cable is not permitted.

SHIPPING & RECEIVING OF EXHIBITOR MATERIALS/PRODUCT

- The facility is unable to accept any goods shipped to the building for show management or any exhibiting company. Your OSC will handle the shipping and receiving of all goods.

SOUND LEVELS

- The LVCVA retains the right to regulate the volume of any sound, whether it be music, voice, or special or artificial effects to the extent that the same interferes with other lessees within the facilities.

VEHICLES ON DISPLAY

- Fuel-tank openings shall be locked or sealed in an approved manner to prevent escape of vapors.
- Fuel is limited to one-quarter its tank or five gallons of fuel, whichever is less.
- At least one battery cable shall be removed from the batteries used to start the vehicle engine, and the disconnected battery cable shall then be taped. Batteries required to demonstrate auxiliary equipment shall be permitted to be kept in service.
- Auxiliary batteries not connected to engine starting system may be left connected.
- Electric and hybrid vehicles shall have their operating batteries disconnected whenever possible. See below for more information.
- External chargers or batteries are recommended for demonstration purposes.
- No battery charging is permitted inside the building.
- Combustible/flammable materials must not be stored beneath display vehicles.
- Fueling or defueling of vehicles is prohibited. Outdoor defueling requires a permit and must follow CCFD guidelines. Contact your CSM for more information.

- Vehicles shall not be moved during show hours.
- 36 inches of clear access or aisles must be maintained around the vehicle.
- Vehicles must be a minimum of 20 feet from exit of door or exit pathway.
- Vehicles placed in lobbies and meeting rooms must have approval of the CSM.
Visqueen must be used under vehicles on display in lobbies and meeting rooms.

Electrical Vehicles (EV)

- The following are requirements that each exhibitor must follow to ensure the protection of life and property. If you have any questions or request exemptions, please contact your Convention Service Manager.

Electric Vehicles Batteries

- All electric vehicle batteries must be charged in the range of no less than 20% and no higher than 50% while indoors.
- The main battery (high voltage battery pack) must be disconnected while the vehicle is indoors when possible.
- All aftermarket or DIY electric vehicles must disconnect their high voltage battery and 12 Volt battery.

Charging

- Indoor electric vehicle charging is NOT allowed.
- All electric vehicle high voltage batteries must be charged outside in a designated area.
- No unattended battery charging.
- Charging location requirements:
 - Outdoors at least 30 feet from the building.
 - Area must be at least 10 feet from combustible materials, such as freight.
 - There must be a clear path to the charging area in case of emergency.

Exhibition Booth

- All electric vehicles must have at least 10 feet of distance between other electric vehicles.
- Electric vehicles are not allowed inside meeting rooms.
- Electric vehicles are not allowed on the second or third floor of any building.
- Electric vehicles are allowed to be exhibited in first- floor lobbies and atriums.

Note: All non-commercially produced electric vehicles will be approved to be exhibited in lobbies and atriums on a case-by-case basis.

The [Electric Vehicle Display form](#) must be completed and submitted to boothplans@lvcca.com for each electric vehicle exhibited.

WEAPONS

- A personal or concealed weapon of any type is not permitted anywhere on the campus of the LVCC.
- Nevada Revised Statute 202.3673 prohibits concealed weapons of any type on facility property.

For more information regarding the Las Vegas Convention Center facility, please view the [LVCC Facility Guide](#) on our website.

Event Name: _____
 Event Start Date: _____
 Event End Date: _____
 Booth/Room #: _____
 On-Site Contact: _____
 Cell #: _____
 On-Site Contact Email Address: _____

Company Name: _____
 Billing Name: _____
 Billing Address: _____
 City: _____ State: _____ Zip: _____
 Country: _____
 Phone #: _____
 Billing Contact Email Address: _____

Cox Business has a full list of products beyond the WiFi Hotspot services listed below.
 Please contact us to discuss any additional needs you may have.

Advanced rate is only available if order is placed and paid 30 days prior to listed event start date. An expedite fee of 20% will be added to standard rates if an order is placed 72 hours or less before the listed event start date.

WiFi Hotspots

Service will be available a day before the event through a day after the event in one specific area serviced by one WiFi access point.

| | Advanced Rate | Standard Rate | Quantity |
|---|---------------|---------------|--------------------------|
| WiFi Hotspot: 5 Mbps, up to 10 Users | \$1,750 | \$2,100 | <input type="checkbox"/> |
| WiFi Hotspot: 5 Mbps, up to 25 Users | \$2,500 | \$3,000 | <input type="checkbox"/> |
| WiFi Hotspot: 5 Mbps, up to 50 Users | \$3,000 | \$3,600 | <input type="checkbox"/> |
| WiFi Hotspot: 5 Mbps, up to 100 Users* | \$4,000 | \$4,800 | <input type="checkbox"/> |
| *Additional Block of 50 Users (Available only with WiFi Hotspot of 100 Users) | \$1,750 | \$2,100 | <input type="checkbox"/> |
| WiFi Hotspot: 10 Mbps, up to 10 Users | \$2,000 | \$2,400 | <input type="checkbox"/> |
| WiFi Hotspot: 10 Mbps, up to 25 Users | \$3,000 | \$3,600 | <input type="checkbox"/> |
| WiFi Hotspot: 10 Mbps, up to 50 Users | \$4,000 | \$4,800 | <input type="checkbox"/> |
| WiFi Hotspot: 10 Mbps, up to 100 Users* | \$5,000 | \$6,000 | <input type="checkbox"/> |
| *Additional Block of 50 Users (Available only with WiFi Hotspot of 100 Users) | \$2,000 | \$2,400 | <input type="checkbox"/> |

Additional Services

| | | | |
|----------------------|-------|-------|--------------------------|
| Outside Distance Fee | \$250 | \$300 | <input type="checkbox"/> |
|----------------------|-------|-------|--------------------------|

Total: _____

802.11ax (WiFi 6) network standard, the latest in WiFi 5ghz

Customer SSID and Password

Customer SSID

Customer Password (WPA2 Key) minimum 12 characters and case sensitive.

Please email your completed form to lvcc.orders@cox.com. Once your order is received you will be contacted by one of our customer service representatives to confirm your services and to process payment.

TERMS AND CONDITIONS OF SERVICE

1. Service and Installation Cox Communications Las Vegas, Inc. d/b/a Cox Business ("Cox"), shall provide Customer with certain services ("Services") and equipment ("Equipment") as described on the first page for the use of Customer and Customer's agents, independent contractors and guests attending or participating in an event hosted by Customer ("Customer's Guest"). Customer understands that Cox is the exclusive provider of all Voice, Data and Video services at the Las Vegas Convention Center (collectively, the "Facility"). Furthermore, Cox is the exclusive provider at the Facility of all floor work associated with the extension of telecommunications and networking services, including, without limitation, coax, fiber or any cabling that transmits voice, data or video. Customer shall be responsible for the acts of Customer's Guests in connection with the Services as if such acts were performed by Customer. Except to the extent caused by Cox, a Cox agent or subcontractor, Customer shall be responsible for damage to any Equipment provided hereunder. Neither Customer nor any Customer Guest may use the Services in any manner that interferes with or impairs any Cox network, whether wired or wireless, Equipment or facilities. The Equipment may be used only for the purpose of receiving the Services. For Cox Internet services, bandwidth speed options may vary. Customer acknowledges and agrees that Customer and Customer's Guests may not always receive or obtain optimal bandwidth speeds and Cox network management needs may require Cox to modify upstream and downstream speeds.

2. Service Date and Term This Agreement shall be effective upon execution by the parties. Services shall be provided beginning on the Event Start Date and ending on the Event End Date, as described on the first page of this Agreement. Cox shall use reasonable efforts to make the Services available by the Event Start Date; provided, however, that Cox shall not be liable for any damages whatsoever resulting from delays in meeting any service dates due to delays beyond its reasonable control.

3. Customer Responsibilities Customer shall ensure that Customer and Customer's Guests use the Services in compliance with all applicable laws and ordinances, as well as applicable leases and other contractual agreements between Customer and third parties. If Customer is purchasing access codes enabling Customer or Customer's Guests to access the Internet, such individuals will be required to agree to the terms of a Cox end user license agreement before accessing the Internet. If Customer is purchasing bandwidth and itself controlling access to the Internet, Customer agrees to require all individuals accessing the Internet to agree to the terms of an end user license agreement reasonably acceptable to Cox. Customer is responsible for ensuring that all Customer and Customer Guest equipment is compatible for the Services selected and with the Cox network.

4. Equipment Unless otherwise provided herein, Customer agrees that Cox shall retain all rights, title and interest to facilities and Equipment installed by Cox hereunder and that Customer shall not create or permit to be created any liens or encumbrances on such Equipment. Cox shall install Equipment necessary to furnish the Services to Customer. Customer shall not modify or relocate Equipment installed by Cox without the prior written consent of Cox. Customer shall not permit tampering, altering or repair of the Equipment by any person other than Cox's authorized personnel. For Cox-owned Equipment, Customer shall, at the expiration or termination of this Agreement, return the Equipment in good condition, ordinary wear and tear resulting from proper use excepted. In the event the Equipment is not returned to Cox in good condition, Customer shall be responsible for the value of such Equipment as provided on the first page of this Agreement, or if no such value is provided, for the replacement cost of such Equipment. Cox shall repair any Equipment owned by Cox at no charge to Customer provided that damage is not due to the negligence or intentional misconduct of Customer. If additional equipment not listed on the first page of this Agreement, including but not limited to, televisions, monitors, computers, circuits, software or other devices, are required by Customer to use the Services, Customer shall be responsible for such equipment.

5. Resale of Service Neither Customer nor any Customer Guest may resell any portion of the Services to any other party.

6. Default If Customer or any Customer Guest fails to comply with any material provision of this Agreement, including, but not limited to failure to make payment as specified, then Cox, at its sole option, may elect to pursue one or more of the following courses of action upon proper notice to Customer as required by applicable law: (i) terminate service whereupon all sums then due and payable shall become immediately due and payable, (ii) suspend all or any part of Services, and/or (iii) pursue any other remedies, including reasonable attorneys' fees, as may be provided at law or in equity, including the applicable termination liabilities.

7. Termination Cox reserves the right to require Customer to pay an early termination fee equal to 10% of the Cox services ordered, if Customer cancels an order after the order is placed, but before the installation date. No refunds will be provided to orders which are canceled after they have been installed. Wireless devices not authorized by Cox are prohibited. Use of any device that interferes with Cox's network is prohibited. If there is signal interference, Cox may terminate this Agreement if Cox cannot resolve the interference by using commercially reasonable efforts. If Cox loses its right to sell Services at the Facility, Cox may assign this Agreement to a third party or terminate this Agreement by providing written notice to Customer and by refunding all prepaid amounts to Customer.

8. LIMITATION OF LIABILITY COX SHALL NOT BE LIABLE FOR DAMAGES FOR FAILURE TO FURNISH OR INTERRUPTION OF ANY SERVICES, NOR SHALL COX BE RESPONSIBLE FOR FAILURE OR ERRORS IN SIGNAL TRANSMISSION, LOST DATA, FILES OR SOFTWARE DAMAGE REGARDLESS OF THE CAUSE. COX SHALL NOT BE LIABLE FOR DAMAGE TO PROPERTY OR FOR INJURY TO ANY PERSON ARISING FROM THE INSTALLATION OR REMOVAL OF EQUIPMENT UNLESS CAUSED BY THE NEGLIGENCE OF COX. UNDER NO CIRCUMSTANCES WILL COX BE LIABLE FOR ANY INDIRECT, INCIDENTAL, PUNITIVE, SPECIAL OR CONSEQUENTIAL DAMAGES INCLUDING LOST PROFITS ARISING FROM THIS AGREEMENT. COX'S MAXIMUM LIABILITY TO CUSTOMER ARISING UNDER THIS AGREEMENT SHALL BE THE LESSER OF \$5,000.00 OR THE AMOUNT ACTUALLY PAID BY CUSTOMER FOR SERVICES HEREUNDER.

9. Assignment Customer may not assign, in whole or in part, this Agreement without the prior written consent of Cox, which consent may be withheld in Cox's discretion. Cox may assign this Agreement and Service may be provided by one or more legally authorized Cox affiliates.

10. WARRANTIES EXCEPT AS PROVIDED HEREIN, THERE ARE NO AGREEMENTS, WARRANTIES OR REPRESENTATIONS, EXPRESS OR IMPLIED, EITHER IN FACT OR BY OPERATION OF LAW, STATUTORY OR OTHERWISE, INCLUDING WARRANTIES OF MERCHANTABILITY AND FITNESS FOR A PARTICULAR PURPOSE, RELATING TO THE SERVICES. SERVICES PROVIDED ARE A BEST EFFORTS SERVICE AND COX DOES NOT WARRANT THAT THE SERVICES, EQUIPMENT OR SOFTWARE SHALL BE ERROR-FREE OR WITHOUT INTERRUPTION. COX MAKES NO WARRANTY AS TO TRANSMISSION OR UPSTREAM OR DOWNSTREAM SPEEDS OF THE NETWORK.

11. INDEMNITY Customer shall indemnify and hold Cox and its respective affiliates, subcontractors, employees and agents harmless (including payment of reasonable attorney's fees) from and against any claims, actions or demands relating to or arising out of Customer's or Customer's Guests use of the Service including without limitation (i) any content or software displayed, distributed or otherwise disseminated by Customer, its employees, or Customer's Guests or (ii) any malicious act or act in violation of any laws committed by Customer, its employees or Customer's Guests.

12. Viruses, Content, Customer Information Software or content obtained from the use of Service may contain viruses or other harmful features and Customer is solely responsible for protecting Customer and Customer's guests' networks, equipment and software through the use of firewalls, anti-virus, and other security devices. Through the use of the Service, Customer may obtain or discover content that is offensive or illegal and Customer assumes the risk and is solely responsible for its access to such content. Cox may disclose Customer information to law enforcement or to any Cox affiliate. Cox may delete any Internet traffic or e-mail that contains a virus. If Customer operates a wireless local access network in connection with the Services, Customer is solely responsible for the security of its network.

13. Public Performance If Customer engages in a public performance of any copyrighted material through use of the Services provided under this Agreement, the Customer, and not Cox, shall be responsible for obtaining any public performing licenses. Any Video Service that Cox provides under this Agreement does not include a public performance license.

14. Regulatory Authority-Force Majeure This Agreement and the obligations of the parties shall be subject to modification to comply with all applicable laws, regulations, court rulings, and administrative orders, as amended. In no event shall either party have any claim against the other for failure of performance if such failure is caused by acts of God, natural disasters including fire, flood, or winds, civil or military action, including riots, civil insurrections or acts of terrorists or the taking of property by condemnation.

15. Miscellaneous This Agreement constitutes the entire agreement between Cox and Customer for the Services and equipment provided herein. The invalidity or unenforceability of any term or condition of this Agreement shall not affect the validity or enforceability of any other provision. Except as provided herein, this Agreement may be modified, waived or amended only by a written amendment signed by both parties. The rights and obligations of the parties under this Agreement shall be governed by the laws of the State of Nevada. The failure by either party to exercise one or more rights provided in this Agreement shall not be deemed a waiver of the right to exercise such right in the future. Notices required by this Agreement shall be in writing and shall be delivered either by personal delivery or by mail. If delivered by mail, notices shall be sent by any express mail service; or by certified or registered mail, return receipt requested; with all postage and charges prepaid. All notices and other written communications under this Agreement shall be addressed to the parties at the addresses on the first page of this Agreement, or as specified by subsequent written notice delivered by the party whose address has changed. Any provision that should by its nature survive the termination or expiration of this Agreement shall survive such termination or expiration. Cox network management needs may require Cox to modify upstream and downstream speeds. Use of the data, Internet, web conferencing/web hosting Services is subject to the "AUP" at <http://ww2.cox.com/aboutus/policies/business-policies.cox>. Certain Services are regulated by the FCC and the Nevada Public Utility Commission and subject to the "Nevada Service Guide" at <http://ww2.cox.com/business/voice/regulatory.cox>. The "General Terms" posted at <http://ww2.cox.com/aboutus/policies/business-general-terms.cox>, the AUP and the Nevada Service Guide are incorporated herein by reference. Cox, in its sole discretion, may modify, supplement or delete any portion of the General Terms, the AUP or the Nevada Service Guide from time to time, without additional notice to Customer, and any such changes will be effective upon Cox publishing such changes on the applicable website listed above. BY EXECUTING THIS AGREEMENT AND/OR USING OR PAYING FOR THE SERVICES, CUSTOMER ACKNOWLEDGES THAT IT HAS READ, UNDERSTOOD, AND AGREED TO BE BOUND BY THE GENERAL TERMS, the AUP and the Nevada Service Guide. If applicable to the Service, Customer shall pay sales, use, gross receipts, and excise taxes, access fees and all other fees, universal service fund assessments, 911 fees, franchise fees, bypass or other local, state and Federal taxes or charges, and deposits, imposed on the use of the Services. All orders are subject to approval of Cox.

Event Name: _____
 Event Start Date: _____
 Event End Date: _____
 Booth/Room #: _____
 On-Site Contact: _____
 Cell #: _____
 On-Site Contact Email Address: _____

Company Name: _____
 Billing Name: _____
 Billing Address: _____
 City: _____ State: _____ Zip: _____
 Country: _____
 Phone #: _____
 Billing Contact Email Address: _____

Please contact us to discuss any additional needs you may have.

Advanced rate is only available if order is placed and paid 30 days prior to listed event start date. An expedite fee of 20% will be added to standard rates if an order is placed 72 hours or less before the listed event start date.

Voice Services

Phone System Services (Dial "9" for outside call)

| | Advanced Rate | Standard Rate | Quantity |
|--|---------------|---------------|--------------------------|
| Multi-Line (One line with one roll-over line and handset) | \$300 | \$360 | <input type="checkbox"/> |

Phone System Services (Direct Dial)

| | | | |
|--|-------|-------|--------------------------|
| Single Line no features | \$200 | \$240 | <input type="checkbox"/> |
| Single Line with Feature Package, Voicemail and Unlimited Domestic LD | \$300 | \$360 | <input type="checkbox"/> |
| Single Line with Polycom Speakerphone | \$350 | \$420 | <input type="checkbox"/> |

Video Services

Digital or HDTV Service (All channels, excluding Premium and International)

| | Advanced Rate | Standard Rate | Quantity |
|--|---------------|---------------|--------------------------|
| Entire Show (First outlet only, up to 5 days) | \$250 | \$300 | <input type="checkbox"/> |

Additional Services

| | Advanced Rate | Standard Rate | Quantity |
|------------------------------------|---------------|---------------|--------------------------|
| Labor/Floor Work | \$75/hr | \$90/hr | <input type="checkbox"/> |
| Voice Services Distance Fee | \$100 | \$120 | <input type="checkbox"/> |
| Video Services Distance Fee | \$250 | \$300 | <input type="checkbox"/> |

Total: _____

Please email your completed form to lvcc.orders@cox.com. Once your order is received you will be contacted by one of our customer service representatives to confirm your services and to process payment.

Booth Diagram Information - Internet

Please indicate on the grid, the location of your Internet drop(s).
If no location is indicated, Internet drop will be placed in the middle back of the booth.

This booth diagram or a detailed floor plan must be submitted with your order.

Adjacent Booth # _____

| | | | | | | | | | |
|--|--|--|--|--|--|--|--|--|--|
| | | | | | | | | | |
| | | | | | | | | | |
| | | | | | | | | | |
| | | | | | | | | | |
| | | | | | | | | | |
| | | | | | | | | | |
| | | | | | | | | | |
| | | | | | | | | | |
| | | | | | | | | | |
| | | | | | | | | | |

Adjacent Booth # _____

Adjacent Booth # _____

Adjacent Booth # _____

TERMS AND CONDITIONS OF SERVICE

1. Service and Installation Cox Communications Las Vegas, Inc. d/b/a Cox Business ("Cox"), shall provide Customer with certain services ("Services") and equipment ("Equipment") as described on the first page for the use of Customer and Customer's agents, independent contractors and guests attending or participating in an event hosted by Customer ("Customer's Guest"). Customer understands that Cox is the exclusive provider of all Voice, Data and Video services at the Las Vegas Convention Center (collectively, the "Facility"). Furthermore, Cox is the exclusive provider at the Facility of all floor work associated with the extension of telecommunications and networking services, including, without limitation, coax, fiber or any cabling that transmits voice, data or video. Customer shall be responsible for the acts of Customer's Guests in connection with the Services as if such acts were performed by Customer. Except to the extent caused by Cox, a Cox agent or subcontractor, Customer shall be responsible for damage to any Equipment provided hereunder. Neither Customer nor any Customer Guest may use the Services in any manner that interferes with or impairs any Cox network, whether wired or wireless, Equipment or facilities. The Equipment may be used only for the purpose of receiving the Services. For Cox Internet services, bandwidth speed options may vary. Customer acknowledges and agrees that Customer and Customer's Guests may not always receive or obtain optimal bandwidth speeds and Cox network management needs may require Cox to modify upstream and downstream speeds.

2. Service Date and Term This Agreement shall be effective upon execution by the parties. Services shall be provided beginning on the Event Start Date and ending on the Event End Date, as described on the first page of this Agreement. Cox shall use reasonable efforts to make the Services available by the Event Start Date; provided, however, that Cox shall not be liable for any damages whatsoever resulting from delays in meeting any service dates due to delays beyond its reasonable control.

3. Customer Responsibilities Customer shall ensure that Customer and Customer's Guests use the Services in compliance with all applicable laws and ordinances, as well as applicable leases and other contractual agreements between Customer and third parties. If Customer is purchasing access codes enabling Customer or Customer's Guests to access the Internet, such individuals will be required to agree to the terms of a Cox end user license agreement before accessing the Internet. If Customer is purchasing bandwidth and itself controlling access to the Internet, Customer agrees to require all individuals accessing the Internet to agree to the terms of an end user license agreement reasonably acceptable to Cox. Customer is responsible for ensuring that all Customer and Customer Guest equipment is compatible for the Services selected and with the Cox network.

4. Equipment Unless otherwise provided herein, Customer agrees that Cox shall retain all rights, title and interest to facilities and Equipment installed by Cox hereunder and that Customer shall not create or permit to be created any liens or encumbrances on such Equipment. Cox shall install Equipment necessary to furnish the Services to Customer. Customer shall not modify or relocate Equipment installed by Cox without the prior written consent of Cox. Customer shall not permit tampering, altering or repair of the Equipment by any person other than Cox's authorized personnel. For Cox-owned Equipment, Customer shall, at the expiration or termination of this Agreement, return the Equipment in good condition, ordinary wear and tear resulting from proper use excepted. In the event the Equipment is not returned to Cox in good condition, Customer shall be responsible for the value of such Equipment as provided on the first page of this Agreement, or if no such value is provided, for the replacement cost of such Equipment. Cox shall repair any Equipment owned by Cox at no charge to Customer provided that damage is not due to the negligence or intentional misconduct of Customer. If additional equipment not listed on the first page of this Agreement, including but not limited to, televisions, monitors, computers, circuits, software or other devices, are required by Customer to use the Services, Customer shall be responsible for such equipment.

5. Resale of Service Neither Customer nor any Customer Guest may resell any portion of the Services to any other party.

6. Default If Customer or any Customer Guest fails to comply with any material provision of this Agreement, including, but not limited to failure to make payment as specified, then Cox, at its sole option, may elect to pursue one or more of the following courses of action upon proper notice to Customer as required by applicable law: (i) terminate service whereupon all sums then due and payable shall become immediately due and payable, (ii) suspend all or any part of Services, and/or (iii) pursue any other remedies, including reasonable attorneys' fees, as may be provided at law or in equity, including the applicable termination liabilities.

7. Termination Cox reserves the right to require Customer to pay an early termination fee equal to 10% of the Cox services ordered, if Customer cancels an order after the order is placed, but before the installation date. No refunds will be provided to orders which are canceled after they have been installed. Wireless devices not authorized by Cox are prohibited. Use of any device that interferes with Cox's network is prohibited. If there is signal interference, Cox may terminate this Agreement if Cox cannot resolve the interference by using commercially reasonable efforts. If Cox loses its right to sell Services at the Facility, Cox may assign this Agreement to a third party or terminate this Agreement by providing written notice to Customer and by refunding all prepaid amounts to Customer.

8. LIMITATION OF LIABILITY COX SHALL NOT BE LIABLE FOR DAMAGES FOR FAILURE TO FURNISH OR INTERRUPTION OF ANY SERVICES, NOR SHALL COX BE RESPONSIBLE FOR FAILURE OR ERRORS IN SIGNAL TRANSMISSION, LOST DATA, FILES OR SOFTWARE DAMAGE REGARDLESS OF THE CAUSE. COX SHALL NOT BE LIABLE FOR DAMAGE TO PROPERTY OR FOR INJURY TO ANY PERSON ARISING FROM THE INSTALLATION OR REMOVAL OF EQUIPMENT UNLESS CAUSED BY THE NEGLIGENCE OF COX. UNDER NO CIRCUMSTANCES WILL COX BE LIABLE FOR ANY INDIRECT, INCIDENTAL, PUNITIVE, SPECIAL OR CONSEQUENTIAL DAMAGES INCLUDING LOST PROFITS ARISING FROM THIS AGREEMENT. COX'S MAXIMUM LIABILITY TO CUSTOMER ARISING UNDER THIS AGREEMENT SHALL BE THE LESSER OF \$5,000.00 OR THE AMOUNT ACTUALLY PAID BY CUSTOMER FOR SERVICES HEREUNDER.

9. Assignment Customer may not assign, in whole or in part, this Agreement without the prior written consent of Cox, which consent may be withheld in Cox's discretion. Cox may assign this Agreement and Service may be provided by one or more legally authorized Cox affiliates.

10. WARRANTIES EXCEPT AS PROVIDED HEREIN, THERE ARE NO AGREEMENTS, WARRANTIES OR REPRESENTATIONS, EXPRESS OR IMPLIED, EITHER IN FACT OR BY OPERATION OF LAW, STATUTORY OR OTHERWISE, INCLUDING WARRANTIES OF MERCHANTABILITY AND FITNESS FOR A PARTICULAR PURPOSE, RELATING TO THE SERVICES. SERVICES PROVIDED ARE A BEST EFFORTS SERVICE AND COX DOES NOT WARRANT THAT THE SERVICES, EQUIPMENT OR SOFTWARE SHALL BE ERROR-FREE OR WITHOUT INTERRUPTION. COX MAKES NO WARRANTY AS TO TRANSMISSION OR UPSTREAM OR DOWNSTREAM SPEEDS OF THE NETWORK.

11. INDEMNITY Customer shall indemnify and hold Cox and its respective affiliates, subcontractors, employees and agents harmless (including payment of reasonable attorney's fees) from and against any claims, actions or demands relating to or arising out of Customer's or Customer's Guests use of the Service including without limitation (i) any content or software displayed, distributed or otherwise disseminated by Customer, its employees, or Customer's Guests or (ii) any malicious act or act in violation of any laws committed by Customer, its employees or Customer's Guests.

12. Viruses, Content, Customer Information Software or content obtained from the use of Service may contain viruses or other harmful features and Customer is solely responsible for protecting Customer and Customer's guests' networks, equipment and software through the use of firewalls, anti-virus, and other security devices. Through the use of the Service, Customer may obtain or discover content that is offensive or illegal and Customer assumes the risk and is solely responsible for its access to such content. Cox may disclose Customer information to law enforcement or to any Cox affiliate. Cox may delete any Internet traffic or e-mail that contains a virus. If Customer operates a wireless local access network in connection with the Services, Customer is solely responsible for the security of its network.

13. Public Performance If Customer engages in a public performance of any copyrighted material through use of the Services provided under this Agreement, the Customer, and not Cox, shall be responsible for obtaining any public performing licenses. Any Video Service that Cox provides under this Agreement does not include a public performance license.

14. Regulatory Authority-Force Majeure This Agreement and the obligations of the parties shall be subject to modification to comply with all applicable laws, regulations, court rulings, and administrative orders, as amended. In no event shall either party have any claim against the other for failure of performance if such failure is caused by acts of God, natural disasters including fire, flood, or winds, civil or military action, including riots, civil insurrections or acts of terrorists or the taking of property by condemnation.

15. Miscellaneous This Agreement constitutes the entire agreement between Cox and Customer for the Services and equipment provided herein. The invalidity or unenforceability of any term or condition of this Agreement shall not affect the validity or enforceability of any other provision. Except as provided herein, this Agreement may be modified, waived or amended only by a written amendment signed by both parties. The rights and obligations of the parties under this Agreement shall be governed by the laws of the State of Nevada. The failure by either party to exercise one or more rights provided in this Agreement shall not be deemed a waiver of the right to exercise such right in the future. Notices required by this Agreement shall be in writing and shall be delivered either by personal delivery or by mail. If delivered by mail, notices shall be sent by any express mail service; or by certified or registered mail, return receipt requested; with all postage and charges prepaid. All notices and other written communications under this Agreement shall be addressed to the parties at the addresses on the first page of this Agreement, or as specified by subsequent written notice delivered by the party whose address has changed. Any provision that should by its nature survive the termination or expiration of this Agreement shall survive such termination or expiration. Cox network management needs may require Cox to modify upstream and downstream speeds. Use of the data, Internet, web conferencing/web hosting Services is subject to the "AUP" at <http://ww2.cox.com/aboutus/policies/business-policies.cox>. Certain Services are regulated by the FCC and the Nevada Public Utility Commission and subject to the "Nevada Service Guide" at <http://ww2.cox.com/business/voice/regulatory.cox>. The "General Terms" posted at <http://ww2.cox.com/aboutus/policies/business-general-terms.cox>, the AUP and the Nevada Service Guide are incorporated herein by reference. Cox, in its sole discretion, may modify, supplement or delete any portion of the General Terms, the AUP or the Nevada Service Guide from time to time, without additional notice to Customer, and any such changes will be effective upon Cox publishing such changes on the applicable website listed above. BY EXECUTING THIS AGREEMENT AND/OR USING OR PAYING FOR THE SERVICES, CUSTOMER ACKNOWLEDGES THAT IT HAS READ, UNDERSTOOD, AND AGREED TO BE BOUND BY THE GENERAL TERMS, the AUP and the Nevada Service Guide. If applicable to the Service, Customer shall pay sales, use, gross receipts, and excise taxes, access fees and all other fees, universal service fund assessments, 911 fees, franchise fees, bypass or other local, state and Federal taxes or charges, and deposits, imposed on the use of the Services. All orders are subject to approval of Cox.

Event Name: _____
 Event Start Date: _____
 Event End Date: _____
 Booth/Room #: _____
 On-Site Contact: _____
 Cell #: _____
 On-Site Contact Email Address: _____

Company Name: _____
 Billing Name: _____
 Billing Address: _____
 City: _____ State: _____ Zip: _____
 Country: _____
 Phone #: _____
 Billing Contact Email Address: _____

Cox Business has a full list of products beyond the Internet drop services listed below.
 Please contact us to discuss any additional needs you may have.

Advanced rate is only available if order is placed and paid 30 days prior to listed event start date. An expedite fee of 20% will be added to standard rates if an order is placed 72 hours or less before the listed event start date.

Internet/Network Services

Shared Bandwidth DATA Services - routers, servers, and NAT devices are not allowed on shared bandwidth data products (Shared Bandwidth is shared with other Internet users within the Las Vegas Convention Center)

| | Advanced Rate | Standard Rate | Quantity |
|---|---------------|---------------|--------------------------|
| Business Professional: Up to 20 Mbps Single drop with 1 private (NAT) IP address. Order up to 20 total IP addresses. Best connection that is shared with other customers. | \$1,200 | \$1,440 | <input type="checkbox"/> |
| Business Select: Up to 10 Mbps Single drop with 1 private (NAT) IP address. Order up to 10 total IP addresses. Up to 10 Mbps connection that is shared with other customers. | \$750 | \$900 | <input type="checkbox"/> |
| Business Starter: Up to 3 Mbps Single drop with 1 private (NAT) IP address. Order up to 3 total IP addresses. Basic connection that is shared with other customers. | \$500 | \$600 | <input type="checkbox"/> |

Dedicated Bandwidth Services (Dedicated Bandwidth, Not Shared)

| | Advanced Rate | Standard Rate | Quantity |
|---|------------------|------------------|--------------------------|
| High Bandwidth Internet speeds from 300 Mbps up to 10 Gbps are available | Call for pricing | Call for pricing | <input type="checkbox"/> |
| Business Professional Plus: 200 Mbps Single drop with 3 public IP addresses. Order up to 20 total IP addresses. Dedicated connection, not shared. | \$45,000 | \$54,000 | <input type="checkbox"/> |
| Business Professional Plus: 100 Mbps Single drop with 3 public IP addresses. Order up to 20 total IP addresses. Dedicated connection, not shared. | \$30,000 | \$36,000 | <input type="checkbox"/> |
| Business Professional Plus: 50 Mbps Single drop with 3 public IP addresses. Order up to 20 total IP addresses. Dedicated connection, not shared. | \$20,000 | \$24,000 | <input type="checkbox"/> |
| Business Professional Plus: 25 Mbps Single drop with 3 public IP addresses. Order up to 20 total IP addresses. Dedicated connection, not shared, best option for large data transfers, video uploads, and downloads. | \$10,000 | \$12,000 | <input type="checkbox"/> |
| Business Select Plus: 10 Mbps Single drop with 3 public IP addresses. Order up to 10 total IP addresses. Dedicated connection, not shared, good for robust browsing, video and audio streaming. | \$4,500 | \$5,400 | <input type="checkbox"/> |
| Business Starter Plus: 5 Mbps Single drop with 3 public IP addresses. No additional IP addresses allowed. Dedicated connection, not shared, good for robust web browsing. | \$2,500 | \$3,000 | <input type="checkbox"/> |

Additional Products and Services

| | Advanced Rate | Standard Rate | Quantity |
|--|---------------|---------------|--------------------------|
| Patch Cables - Ethernet Cat 5 Cable | \$60 each | \$72 each | <input type="checkbox"/> |
| Switch Rental - Up to 24 port (10/100 unmanaged) | \$150 each | \$180 each | <input type="checkbox"/> |
| Additional IP Address | \$100 each | \$120 each | <input type="checkbox"/> |
| Additional Locations - Additional drop for dedicated bandwidth products only. | \$500 each | \$600 each | <input type="checkbox"/> |
| Labor/Floor Work | \$75/hour | \$90/hour | <input type="checkbox"/> |
| Outside Distance Fee | \$250 | \$300 | <input type="checkbox"/> |

Total: _____

Please email your completed form to lvcc.orders@cox.com. Once your order is received you will be contacted by one of our customer service representatives to confirm your services and to process payment.

Booth Diagram Information - Internet

Please indicate on the grid, the location of your Internet drop(s).
If no location is indicated, Internet drop will be placed in the middle back of the booth.

This booth diagram or a detailed floor plan must be submitted with your order.

Adjacent Booth # _____

| | | | | | | | | | |
|--|--|--|--|--|--|--|--|--|--|
| | | | | | | | | | |
| | | | | | | | | | |
| | | | | | | | | | |
| | | | | | | | | | |
| | | | | | | | | | |
| | | | | | | | | | |
| | | | | | | | | | |
| | | | | | | | | | |
| | | | | | | | | | |
| | | | | | | | | | |

Adjacent Booth # _____

Adjacent Booth # _____

Adjacent Booth # _____

TERMS AND CONDITIONS OF SERVICE

1. Service and Installation Cox Communications Las Vegas, Inc. d/b/a Cox Business ("Cox"), shall provide Customer with certain services ("Services") and equipment ("Equipment") as described on the first page for the use of Customer and Customer's agents, independent contractors and guests attending or participating in an event hosted by Customer ("Customer's Guest"). Customer understands that Cox is the exclusive provider of all Voice, Data and Video services at the Las Vegas Convention Center (collectively, the "Facility"). Furthermore, Cox is the exclusive provider at the Facility of all floor work associated with the extension of telecommunications and networking services, including, without limitation, coax, fiber or any cabling that transmits voice, data or video. Customer shall be responsible for the acts of Customer's Guests in connection with the Services as if such acts were performed by Customer. Except to the extent caused by Cox, a Cox agent or subcontractor, Customer shall be responsible for damage to any Equipment provided hereunder. Neither Customer nor any Customer Guest may use the Services in any manner that interferes with or impairs any Cox network, whether wired or wireless, Equipment or facilities. The Equipment may be used only for the purpose of receiving the Services. For Cox Internet services, bandwidth speed options may vary. Customer acknowledges and agrees that Customer and Customer's Guests may not always receive or obtain optimal bandwidth speeds and Cox network management needs may require Cox to modify upstream and downstream speeds.

2. Service Date and Term This Agreement shall be effective upon execution by the parties. Services shall be provided beginning on the Event Start Date and ending on the Event End Date, as described on the first page of this Agreement. Cox shall use reasonable efforts to make the Services available by the Event Start Date; provided, however, that Cox shall not be liable for any damages whatsoever resulting from delays in meeting any service dates due to delays beyond its reasonable control.

3. Customer Responsibilities Customer shall ensure that Customer and Customer's Guests use the Services in compliance with all applicable laws and ordinances, as well as applicable leases and other contractual agreements between Customer and third parties. If Customer is purchasing access codes enabling Customer or Customer's Guests to access the Internet, such individuals will be required to agree to the terms of a Cox end user license agreement before accessing the Internet. If Customer is purchasing bandwidth and itself controlling access to the Internet, Customer agrees to require all individuals accessing the Internet to agree to the terms of an end user license agreement reasonably acceptable to Cox. Customer is responsible for ensuring that all Customer and Customer Guest equipment is compatible for the Services selected and with the Cox network.

4. Equipment Unless otherwise provided herein, Customer agrees that Cox shall retain all rights, title and interest to facilities and Equipment installed by Cox hereunder and that Customer shall not create or permit to be created any liens or encumbrances on such Equipment. Cox shall install Equipment necessary to furnish the Services to Customer. Customer shall not modify or relocate Equipment installed by Cox without the prior written consent of Cox. Customer shall not permit tampering, altering or repair of the Equipment by any person other than Cox's authorized personnel. For Cox-owned Equipment, Customer shall, at the expiration or termination of this Agreement, return the Equipment in good condition, ordinary wear and tear resulting from proper use excepted. In the event the Equipment is not returned to Cox in good condition, Customer shall be responsible for the value of such Equipment as provided on the first page of this Agreement, or if no such value is provided, for the replacement cost of such Equipment. Cox shall repair any Equipment owned by Cox at no charge to Customer provided that damage is not due to the negligence or intentional misconduct of Customer. If additional equipment not listed on the first page of this Agreement, including but not limited to, televisions, monitors, computers, circuits, software or other devices, are required by Customer to use the Services, Customer shall be responsible for such equipment.

5. Resale of Service Neither Customer nor any Customer Guest may resell any portion of the Services to any other party.

6. Default If Customer or any Customer Guest fails to comply with any material provision of this Agreement, including, but not limited to failure to make payment as specified, then Cox, at its sole option, may elect to pursue one or more of the following courses of action upon proper notice to Customer as required by applicable law: (i) terminate service whereupon all sums then due and payable shall become immediately due and payable, (ii) suspend all or any part of Services, and/or (iii) pursue any other remedies, including reasonable attorneys' fees, as may be provided at law or in equity, including the applicable termination liabilities.

7. Termination Cox reserves the right to require Customer to pay an early termination fee equal to 10% of the Cox services ordered, if Customer cancels an order after the order is placed, but before the installation date. No refunds will be provided to orders which are canceled after they have been installed. Wireless devices not authorized by Cox are prohibited. Use of any device that interferes with Cox's network is prohibited. If there is signal interference, Cox may terminate this Agreement if Cox cannot resolve the interference by using commercially reasonable efforts. If Cox loses its right to sell Services at the Facility, Cox may assign this Agreement to a third party or terminate this Agreement by providing written notice to Customer and by refunding all prepaid amounts to Customer.

8. LIMITATION OF LIABILITY COX SHALL NOT BE LIABLE FOR DAMAGES FOR FAILURE TO FURNISH OR INTERRUPTION OF ANY SERVICES, NOR SHALL COX BE RESPONSIBLE FOR FAILURE OR ERRORS IN SIGNAL TRANSMISSION, LOST DATA, FILES OR SOFTWARE DAMAGE REGARDLESS OF THE CAUSE. COX SHALL NOT BE LIABLE FOR DAMAGE TO PROPERTY OR FOR INJURY TO ANY PERSON ARISING FROM THE INSTALLATION OR REMOVAL OF EQUIPMENT UNLESS CAUSED BY THE NEGLIGENCE OF COX. UNDER NO CIRCUMSTANCES WILL COX BE LIABLE FOR ANY INDIRECT, INCIDENTAL, PUNITIVE, SPECIAL OR CONSEQUENTIAL DAMAGES INCLUDING LOST PROFITS ARISING FROM THIS AGREEMENT. COX'S MAXIMUM LIABILITY TO CUSTOMER ARISING UNDER THIS AGREEMENT SHALL BE THE LESSER OF \$5,000.00 OR THE AMOUNT ACTUALLY PAID BY CUSTOMER FOR SERVICES HEREUNDER.

9. Assignment Customer may not assign, in whole or in part, this Agreement without the prior written consent of Cox, which consent may be withheld in Cox's discretion. Cox may assign this Agreement and Service may be provided by one or more legally authorized Cox affiliates.

10. WARRANTIES EXCEPT AS PROVIDED HEREIN, THERE ARE NO AGREEMENTS, WARRANTIES OR REPRESENTATIONS, EXPRESS OR IMPLIED, EITHER IN FACT OR BY OPERATION OF LAW, STATUTORY OR OTHERWISE, INCLUDING WARRANTIES OF MERCHANTABILITY AND FITNESS FOR A PARTICULAR PURPOSE, RELATING TO THE SERVICES. SERVICES PROVIDED ARE A BEST EFFORTS SERVICE AND COX DOES NOT WARRANT THAT THE SERVICES, EQUIPMENT OR SOFTWARE SHALL BE ERROR-FREE OR WITHOUT INTERRUPTION. COX MAKES NO WARRANTY AS TO TRANSMISSION OR UPSTREAM OR DOWNSTREAM SPEEDS OF THE NETWORK.

11. INDEMNITY Customer shall indemnify and hold Cox and its respective affiliates, subcontractors, employees and agents harmless (including payment of reasonable attorney's fees) from and against any claims, actions or demands relating to or arising out of Customer's or Customer's Guests use of the Service including without limitation (i) any content or software displayed, distributed or otherwise disseminated by Customer, its employees, or Customer's Guests or (ii) any malicious act or act in violation of any laws committed by Customer, its employees or Customer's Guests.

12. Viruses, Content, Customer Information Software or content obtained from the use of Service may contain viruses or other harmful features and Customer is solely responsible for protecting Customer and Customer's guests' networks, equipment and software through the use of firewalls, anti-virus, and other security devices. Through the use of the Service, Customer may obtain or discover content that is offensive or illegal and Customer assumes the risk and is solely responsible for its access to such content. Cox may disclose Customer information to law enforcement or to any Cox affiliate. Cox may delete any Internet traffic or e-mail that contains a virus. If Customer operates a wireless local access network in connection with the Services, Customer is solely responsible for the security of its network.

13. Public Performance If Customer engages in a public performance of any copyrighted material through use of the Services provided under this Agreement, the Customer, and not Cox, shall be responsible for obtaining any public performing licenses. Any Video Service that Cox provides under this Agreement does not include a public performance license.

14. Regulatory Authority-Force Majeure This Agreement and the obligations of the parties shall be subject to modification to comply with all applicable laws, regulations, court rulings, and administrative orders, as amended. In no event shall either party have any claim against the other for failure of performance if such failure is caused by acts of God, natural disasters including fire, flood, or winds, civil or military action, including riots, civil insurrections or acts of terrorists or the taking of property by condemnation.

15. Miscellaneous This Agreement constitutes the entire agreement between Cox and Customer for the Services and equipment provided herein. The invalidity or unenforceability of any term or condition of this Agreement shall not affect the validity or enforceability of any other provision. Except as provided herein, this Agreement may be modified, waived or amended only by a written amendment signed by both parties. The rights and obligations of the parties under this Agreement shall be governed by the laws of the State of Nevada. The failure by either party to exercise one or more rights provided in this Agreement shall not be deemed a waiver of the right to exercise such right in the future. Notices required by this Agreement shall be in writing and shall be delivered either by personal delivery or by mail. If delivered by mail, notices shall be sent by any express mail service; or by certified or registered mail, return receipt requested; with all postage and charges prepaid. All notices and other written communications under this Agreement shall be addressed to the parties at the addresses on the first page of this Agreement, or as specified by subsequent written notice delivered by the party whose address has changed. Any provision that should by its nature survive the termination or expiration of this Agreement shall survive such termination or expiration. Cox network management needs may require Cox to modify upstream and downstream speeds. Use of the data, Internet, web conferencing/web hosting Services is subject to the "AUP" at <http://ww2.cox.com/aboutus/policies/business-policies.cox>. Certain Services are regulated by the FCC and the Nevada Public Utility Commission and subject to the "Nevada Service Guide" at <http://ww2.cox.com/business/voice/regulatory.cox>. The "General Terms" posted at <http://ww2.cox.com/aboutus/policies/business-general-terms.cox>, the AUP and the Nevada Service Guide are incorporated herein by reference. Cox, in its sole discretion, may modify, supplement or delete any portion of the General Terms, the AUP or the Nevada Service Guide from time to time, without additional notice to Customer, and any such changes will be effective upon Cox publishing such changes on the applicable website listed above. BY EXECUTING THIS AGREEMENT AND/OR USING OR PAYING FOR THE SERVICES, CUSTOMER ACKNOWLEDGES THAT IT HAS READ, UNDERSTOOD, AND AGREED TO BE BOUND BY THE GENERAL TERMS, the AUP and the Nevada Service Guide. If applicable to the Service, Customer shall pay sales, use, gross receipts, and excise taxes, access fees and all other fees, universal service fund assessments, 911 fees, franchise fees, bypass or other local, state and Federal taxes or charges, and deposits, imposed on the use of the Services. All orders are subject to approval of Cox.



| | | | | | |
|-------------------------------------|--|--|------|---|--------------------|
| EVENT NAME: Champs Las Vegas | | EVENT DATES: AUGUST 26-28, 2026 | | FACILITY: Las Vegas Convention Center South Hall | |
| EXHIBITING COMPANY: | | | | | Booth/Room Number: |
| BILLING STREET ADDRESS | | | | | |
| CITY: | | STATE: | ZIP: | COUNTRY: | |
| ORDERED BY: | | | TEL: | FAX: | |
| EMAIL: | | | | | |

ORDERS PLACED AFTER THE START OF SHOW LOAD IN MAY BE SUBJECT TO A \$125.00 SERVICE FEE.

We are always available to help you with your project, for a custom quote or personal assistance please call (702) 897-8508 or Email: rcornish@totalshowtech.com

| | |
|-------------------------------|-----------------------------|
| Requested Delivery Date/Time: | Requested Pickup Date/Time: |
| Show Site Contact: | Cell Phone: |

| QTY | MONITOR or TV PACKAGES <i>With Stand or Wall Mount! (call or email for other sizes or configurations)</i> | SHOW RATE | TOTAL | QTY | HD VIDEO WALL & LED WALLS <i>(call or email for other sizes or configurations)</i> | SHOW RATE | TOTAL |
|---|--|-----------------------|------------------------------|------------------------|---|--|-----------------|
| | 32" HD LED Monitor Circle One: Wall Mount, Floor or Tabletop Stand | \$325.00 | | | Video Wall Package Includes: Wall Mounts or Floor Stands, MacBook Pro with Playback Pro, Image Pro 2 for sizing & Supervisor. (Supervisor Labor included; Set up labor will be quoted or you must order from the Show's General Contractor - IN ACCORDANCE WITH SHOW GUIDELINES) Audio & Additional image Processing are extra | | Request a Quote |
| | 40" 4k LED Monitor Circle One: Wall Mount, Floor or Tabletop Stand | \$475.00 | | | | | |
| | 43" 4k LCD Monitor Circle One: Wall Mount, Floor or Tabletop Stand | \$550.00 | | | | | |
| | 50" 4k LED Monitor Circle One: Wall Mount, Floor or Tabletop Stand | \$650.00 | | | | | |
| | 55" 4k LED Monitor (1920*1080, 4k) Circle One: Wall Mount, Floor or Tabletop Stand | \$750.00 | | | LED Wall beMatrix LEDskin: (2.5mm pixel pitch) LED Wall Absen A3Pro: (3.9mm pixel pitch) | | Request a Quote |
| | 60" 4k LED/Plasma Monitor Circle One: Wall Mount, Floor or Tabletop Stand | \$850.00 | | | TOUCH SCREENS/INTERACTIVE VIDEO Will work natively with Windows 7, 8 or 10. (call or email for other configurations) | | |
| | 65" or 70" 4K LED Monitor (3840*2160, 480 Hz, HDMI; NO VGA) 65" Circle One: Wall Mount, Floor or Tabletop Stand 70" | \$950.00 \$1050.00 | | | 55" 3M Multi-Touch Display (Windows PC included) | \$3,000.00 | |
| | 80" 4k HD Monitor Circle One: Wall Mount, Floor or Tabletop Stand | \$1,500.00 | | | | | Request a Quote |
| | 85" 4k LED Monitor Circle One: Wall Mount, Floor or Tabletop Stand | \$2,500.00 | | | AUDIO EQUIPMENT (call or email for other configurations) | | |
| | VIDEO EQUIPMENT | | | | Sound System 1 Speaker 10"/12" (Speaker(s), Stand(s), Analog Mixer and CD Player or Wireless Mic) Circle One: Wireless Handheld or Lavalier Mic. 2 Speaker 10"/12" | \$365.00 / 400.00 \$550.00 / 550.00 | |
| | 4K Media Player (Play 4K 3840*2160 @ 60 fps) | \$250.00 | | | Compact Mixer: 4 channel Digital (QSC TouchMix/Yamaha TF1) | \$100.00 \$150.00 \$500.00 | |
| | HD Media Player (Play from a USB with Seamless Looping) | \$125.00 | | | 1000w 12" Subwoofer: Turbosound iNSPIRE | \$275.00 | |
| | 72" Dual Post Monitor Floor Stand w/Bracket & Shelf: (Monitor Not Included - for use with Your/Exhibitor's monitor) | \$250.00 | | | Wireless Sound Bar: Samsung (tv audio) | \$200.00 | |
| | Wall Mount: (Monitor Not Included/for Your Monitor; Vesa compliant) | \$125.00 | | | Wireless Microphone Circle one: Handheld or Lavalier | \$200.00 | |
| | VGA to HDMI Converter: KanexPro (Upscales signal to 1080p/60 with Audio) | \$90.00 | | | Headset For Wireless Kit Countryman E6i | \$75.00 | |
| | Mac adaptor kit: (Adapt laptop, tablet, phone video output to work on current monitors) | \$90.00 | | | PCDI Laptop or MP3 Player Audio Interface | \$80.00 | |
| | | | | | 80 Watt 5.5" Speaker, wall mount Behringer CE500A | \$300.00 | |
| | | | | | Technical Assistance available at hourly rates | | Request a Quote |
| | | | | | TOTALS | | |
| | | | | | Projected Equipment Total | | |
| | | | | | Delivery & Pick-Up (Additional Delivery labor may be added on large orders) | \$150.00 | \$150.00 |
| | | | | | Labor (Per Hr.) (Will added to your quote based on your needs) | \$90.00 (OT \$135.00) | TBD |
| | | | | | ESTIMATED TOTAL (You will be sent a formal quote with all our charges for approval before we process any payment) | | |
| | Other: Printers, Fax machines, Projectors, Screens, Lighting, Truss, Staging or other equipment or services | | | | Request a Quote | | |
| LABOR: Days, Monday through Friday (except holidays), will be at the straight time rate between the hours of 8:00 AM and 5:00 PM, all other hours will be at the overtime rate. IN ACCORDANCE WITH SHOW GUIDELINES: ANY LABOR CHARGES BY THE SHOW'S GENERAL CONTRACTOR (DRAYAGE, ELECTRICIANS OR STAGHANDS, ETC.), ARE NOT INCLUDED HEREIN AND WILL BE BILLED DIRECTLY BY THE SHOW'S GENERAL CONTRACTOR TO THE EXHIBITOR. | | | | | | | |
| Pickup & Delivery Labor | Straight Time: \$90.00 | Overtime: \$135.00 | Installation & Removal Labor | Straight Time: \$90.00 | Overtime: \$135.00 | | |
| Supervisor (may be required for large or complex installations) | Straight Time: \$105.00 | | | Overtime: \$157.50 | | | |

BY SIGNING AND DELIVERING THIS FORM TO TST, CUSTOMER AGREES TO ALL TERMS AND CONDITIONS, AND TO ABIDE BY THE TERMS OF PURCHASE CONTRACT. ORDERS CANCELLED UPON OR AFTER DELIVERY ARE SUBJECT TO A CANCELLATION FEE. NO CREDIT WILL BE ISSUED ON SERVICES INSTALLED AND NOT USED OR AFTER SHOW CLOSING.

SEE REVERSE SIDE OF THIS FORM FOR ALL TERMS AND CONDITIONS (20.0 MASTER)

Total Show Technology will require payment in full and a signed copy of this rental agreement prior to the delivery date to insure delivery by the requested date and time.

Client must be available to sign for and accept equipment.

CONTRACT:

TRADE SHOW TECHNICAL, INC. dba Total Show Technology ("TST") agrees to rent their equipment ("Equipment"), subject to the conditions of the Contract, and in consideration thereof, the undersigned Customer ("Renter") agrees to the following:

1. Renter understands and agrees that the Equipment described in the Contract remains the property of TST, and that the failure by the Renter to return said Equipment to TST may constitute a crime and subject Renter to criminal prosecution.
2. Renter acknowledges that he has examined the Equipment and knows the condition thereof, and that the same is in good condition and repair, and Renter agrees he will return the Equipment in the same good condition as when received, ordinary wear and tear excepted.
3. Renter assumes all risks, security interests and encumbrances of loss, theft, destruction, or damage to such Equipment for any reason, and will hold TST harmless from any and all damages, claim, lien, storage costs, labor and materials. Renter further agrees to pay TST on demand all costs of repairs or replacement at the current repair or replacement cost of said Equipment and shall insure each item of Equipment against loss or damage for not less than the replacement value, with no deductibles for depreciation of each item and if requested by TST shall provide evidence of such insurance.
4. TST shall have a lien on all Renters' property for all charges and expenses incurred by TST under the terms of the Contract including those caused by damage to or destruction of said Equipment.
5. All equipment is subject to testing and check-out by TST personal upon return or pick-up to verify said equipment is in the same condition it was delivered in and not damaged in any way.
6. Renter agrees that TST has the right to terminate this agreement at any time, and retake possession of said Equipment, and Renter shall guarantee free access to TST of said Equipment and may enter upon the premises of the Renter, without becoming liable for trespass.
7. RENTER EXPRESSLY AGREES to use Equipment in strict accordance with the following instructions. Failure to do so automatically terminates this Contract, with all sums due hereunder immediately payable to TST. RENTER FURTHER AGREES to immediately return said Equipment.
8. TST SHALL NOT BE LIABLE TO RENTER FOR ANY LIABILITY, CLAIM, LOSS, DAMAGE (DIRECT OR CONSEQUENTIAL), OR EXPENSE OF ANY KIND OR NATURE CAUSED, DIRECTLY OR INDIRECTLY, BY EQUIPMENT OR ANY INADEQUACY THEREOF FOR ANY PURPOSE, OR ANY DEFICIENCY OR ANY DEFECT (LATENT OR PATENT) THEREIN, DELAY IN PROVIDING OR FAILURE TO PROVIDE ANY THEREOF, OR ANY INTERRUPTION OR LOSS OF SERVICE OR USE THEREOF OR ANY LOSS OF BUSINESS, OR ANY DAMAGE WHATSOEVER AND HOWEVER CAUSED BY TST SHALL NOT, BY VIRTUE OF HAVING RENTED THE EQUIPMENT UNDER THIS CONTRACT, BE DEEMED TO HAVE MADE ANY REPRESENTATION OR WARRANTY, WHETHER WRITTEN OR ORAL OR EXPRESSED OR IMPLIED, AS TO THE MERCHANTABILITY, FITNESS (FOR USE OR FOR ANY PARTICULAR), DESIGN OR CONDITION OF, OR AS TO THE QUALITY OF THE MATERIAL OR WORKMANSHIP IN THE EQUIPMENT.
9. SOFTWARE: Equipment includes any software provided therewith. Software shall remain the property of its licensor. The terms and conditions of any software license agreement covering the software are incorporated herein by reference and supersede anything to the contrary herein, and Renter agrees to be bound by such terms and conditions, particularly those limiting the use and transfer of the software. Software is warranted only to the extent provided for directly by the licensor. TST makes no warranty as to the performance of any software. The Renter hereby acknowledges that the applicable Microsoft End User License Agreement governs the use of any Microsoft software accompanying the computer equipment rented.
10. Rental charges shall be based on all or any part of each twenty-four (24) hour period to the following 5:59 a.m. Renter agrees to pay rental fee stipulated for the period stated. If Equipment is kept for a longer period, the rental fee will be charged at the stated rate until the Equipment is returned to the possession of TST.
11. If TST incurs any expenses, including reasonable attorney's fees, in the enforcement of any of its rights hereunder, those costs and expenses shall be the sole obligation of Renter.
12. All orders cancelled during or after delivery are subject to a cancellation fee of (1) days rental at the TST standard daily rates or the quoted show rate whichever is less.
13. Equipment delivery and installation times are prioritized when the completed form is processed through TST. TST is not responsible if equipment installation does not meet your timeline due to any unforeseen circumstances that may occur. The Delivery/Pick Up charge covers delivery to and pick up from the Facility only. Any installation/set up/dismantle work and any moves, additions and changes will be charged at current TST labor rates.
14. Any drayage or forced labor charges will be billed directly to the exhibitor by the show general contractor.
15. TST reserves the right to upgrade equipment at no additional charge.
16. All charges are subject to change without prior notice.
17. Competitor price matching is contingent upon receipt of a written quote and/or an official order form which pertains specifically to the show for which the equipment is being ordered. TST reserves the right to refuse any price match.
18. TST's liability for any professional error, mistake, malpractice or omission shall be limited to our daily rate for this project.
19. No term or condition of this Contract may be waived or modified as to TST except in writing signed by TST's authorized representative or by an officer of TST who has been expressly authorized to do so by TST.
20. Rental of equipment and/or labor constitutes acceptance of all terms and conditions.
21. All labor calls outside of standard business hours of 8AM to 5PM, Monday through Friday, are subject to a 4- hour minimum labor charge at overtime and applicable holiday rates. If there is a return call that is outside the initial 4-hour window, the call is subject to an additional 4-hour minimum labor call.

This Contract constitutes the entire agreement between TST and Renter.



6455 S. Dean Martin Drive, Suite C.
 Las Vegas, Nevada 89118
 Phone: (702) 309-8326 * Fax: (702) 309-8328
 Email: orders@exposervicedesk.com
 Order Online: www.exposervicedesk.com

**ALL ISLANDS
 WILL REQUIRE
 A MINIMUM OF
 20 AMPS**

| | | | | | |
|---|--|------------------------------|-------------------|--|--|
| EVENT NAME: CHAMPS – AUGUST 2026 | | EVENT DATES: AUG 26-28, 2026 | | LOCATION: LVCC / SOUTH HALL | |
| EXHIBITING COMPANY NAME: | | | | BOOTH NUMBER: | |
| BILLING NAME (if different from above): | | | | Deadline for Advance Rate: AUGUST 12, 2026 | |
| BILLING ADDRESS: | | | | | |
| CITY: | | STATE: | | ZIP CODE: | |
| TELEPHONE: | | | FAX: | | |
| CARDHOLDER SIGNATURE: | | | CARDHOLDER PRINT: | | |
| | | | ORDERED BY: | | |
| EMAIL (REQUIRED FOR RECEIPT): | | | | | |
| WE ACCEPT: VISA / MASTERCARD / AMERICAN EXPRESS | | CVV: | | EXPIRATION DATE: | |
| (CC # HERE) | | | | | |

CHARGES WILL APPEAR ON STATEMENT AS "TEAM CO"

| QTY | Description | Advance Rate | Late | On-Site | Total | | | |
|--|---|-----------------------|---------|---------|-------|---|-----|----------|
| 120V LIGHTING & UTILITY OUTLETS | | | | | | Convention Technical Services (CTS) is not responsible for voltage fluctuation or power failure due to temporary conditions including but not limited to losses due to utility company failure, permanent power distribution failure, power failure caused by vandalism, faulty exhibitor equipment or overloads caused by exhibitor. For your protection you should install a surge protector on your computer(s). All electrical installations and connections to all electrical service should be made by a CTS technician. CTS will not be responsible for any damage or loss to any equipment component, computer hardware or software, and/or any damage or injury to any person caused by the installation, connection or plugging in of any electrical outlet by persons other than a CTS technician. | | |
| | 500 Watt or 5 Amps | 109.00 | 163.50 | 245.00 | | | | |
| | 1000 Watt or 10 Amps | 193.00 | 289.50 | 434.00 | | | | |
| | 2000 Watt or 20 Amps | 257.50 | 386.00 | 579.00 | | | | |
| | 30 Amp (Cannot be split. Powers one item only.) | CALL FOR QUOTE | | | | | | |
| 208V 1 PHASE MOTOR & EQUIPMENT OUNETLETS | | | | | | CTS does not determine the move-in and move-out schedule for any event. Hourly rates apply to actual dates and times of install & dismantle. ST – Labor after 8:00am and before 4:30pm, weekdays. OT – Labor before 8:00am and after 4:30pm weekdays. Weekends & Holidays are also OT. | | |
| | 20 Amp | 485.50 | 728.00 | 1092.00 | | | | |
| | 30 Amp | 581.00 | 871.50 | 1307.00 | | | | |
| | 60 Amp | 761.00 | 1141.50 | 1712.00 | | | | |
| | 100 Amp | 1000.50 | 1501.00 | 2251.50 | | | | |
| 208V 3 PHASE MOTOR & EQUIPMENT OUTLETS | | | | | | Important: To receive advance show prices, we must receive your order, along with payment in full, within fourteen (14) days prior to show opening. All others will be charged at regular rate. NO EXCEPTION. Any connection required beyond the finished outlet will be charged for time and materials. If you have special needs, please contact us in advance of move-in. Power sharing is NOT permitted between exhibitors. Exhibitors are not permitted to use power unless ordered. Exhibitors found using outlets without an order will be subject to on-site rates. | | |
| | 20 Amp | 647.50 | 971.00 | 1456.50 | | | | |
| | 30 Amp | 774.00 | 1161.00 | 1741.50 | | | | |
| | 60 Amp | 1014.50 | 1522.00 | 2283.00 | | | | |
| | 100 Amp | 1333.50 | 2000.00 | 3000.00 | | | | |
| | 200 Amp | 1909.00 | 2863.50 | 4295.00 | | | | |
| LIGHTING | | | | | | Lift & Crew (per hour w/ 1 hour minimum): ST - \$475.00 / OT – \$615.00 | | |
| | 150-Watt Flood Light | 109.00 | 163.50 | 245.00 | | | | |
| | Double 150-Watt Flood | 181.00 | 271.50 | 407.00 | | | | |
| | Overhead – Leko/Par* | 302.00 | 453.00 | 679.50 | | | | |
| *Overhead light may require labor and lift to install. Call for a quote. Lighting layout required for overhead lights. | | | | | | Labor Rates (per hour / per person) | | |
| Total for Electrical & Lighting | | | | | ST: | \$130.00 | OT: | \$200.00 |

Terms Cont'd

| | | |
|--|--|---|
| Electricity will be turned on within 30 minutes of show opening and off within 30 minutes after show closing. Dedicated circuits and 24-hour services will be double the listed price and require a 20-amp outlet. Please indicate 24 hours on form. Refunds will not be authorized if outlet is already installed. Electrical labor required on all 208V & higher outlets. | Island Booths: will require labor and materials. Distribution and connections of all outlets are chargeable. Please fill in a layout w/ main drop, orientation & dimensions, and return w/ order. All other booth types: All power is delivered to the back line of the booth at no extra cost. Labor only applies to additional distribution on a time and materials basis. Please fill in a layout and return with order. No layout. No installation. | ATTENTION: **All Island booths will require a minimum of 20 Amps. ** All ON-SITE orders that require labor, lift & crew will be billed at OVERTIME rates. |
| | | Jurisdiction: -All under carpet distribution. -All motor & equipment hook-ups requiring wiring connections. -Labor is required to inspect equipment pre-wired to plug into our system. -Installation and/or repair of electrical fixtures. -Installation of electrical motors and electrical apparatus to be energized. |

6455 S. Dean Martin Dr., Suite C * Las Vegas, Nevada 89118
 Telephone: (702) 309-8326

Sample Layouts

Island Booth: Electrical layouts are required for all island booths.

Standard Location:

There is no such thing as a standard location in an island booth. There will be labor and material required to install the outlet ordered. If a layout is not provided, we will place power at our discretion.

What should be on a completed floor plan:

1. Main drop or outlet location. Island booths do not have a back wall so the main location operates as the point which all other power will be distributed from. There can often be many cords or cables in this location so it is often best to be in a closet, under a table or a location out of site.
2. Location of all other outlets. This includes the dimensions where the outlets will be placed. Without dimensions, outlets are likely to end up in the wrong locations in the booth.
3. Power requirements in each location. This can be 500 Watts / 1000 Watts / 2000 Watts or even 10 Amp 208 volt 3 Phase
4. Booth Orientation. This is especially useful for island booths. It helps us understand which side is which in the booth.

Completed Layout:

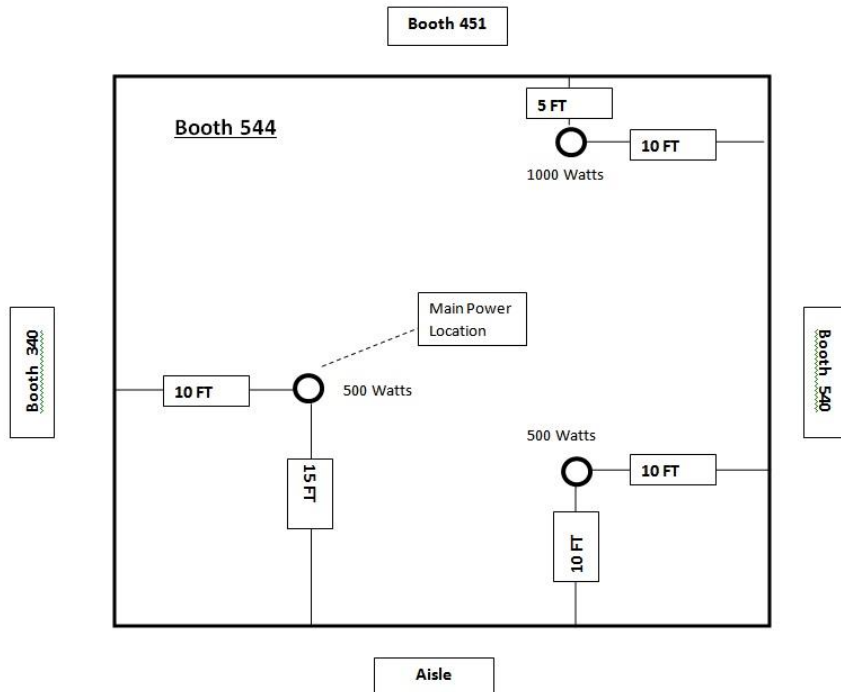

Inline or Peninsula Booths:

Layouts are only required when outlets are needed at any other location than the back of the booth.

Standard Location:

In Line

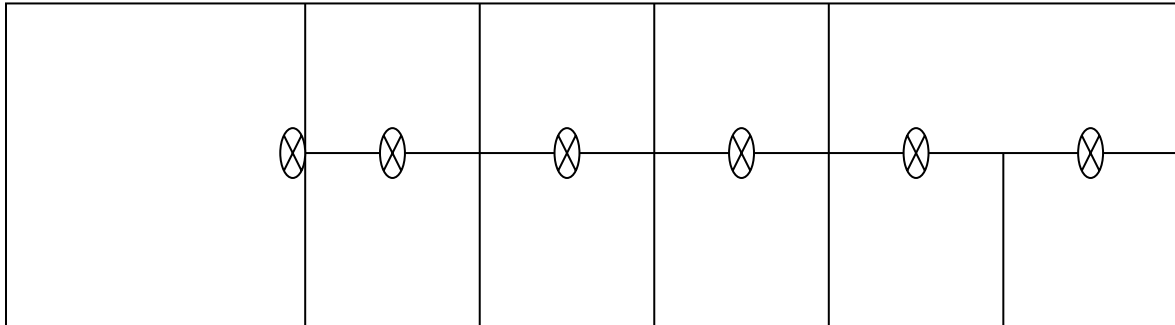

Completed Layout:

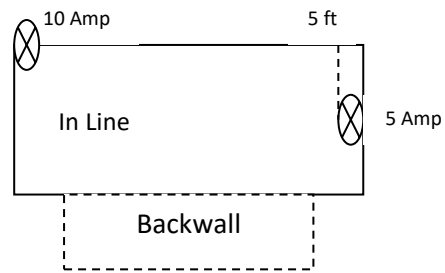
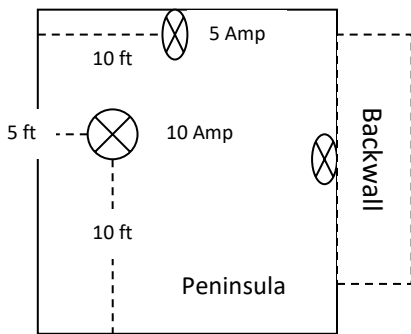

Thank you for your business!